





# CORVETTE

**1980**

**SPECIFICATIONS**

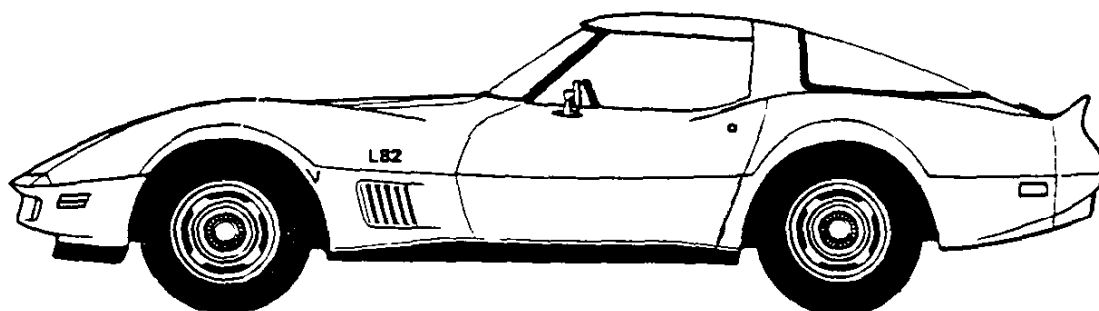

**GENUINE CHEVROLET**



# 1980 CORVETTE

Production: 40,614 coupes

## 1980 NUMBERS

**Vehicle:** 1Z87BAS400001 through 1Z87BAS440614

- Fifth digit varies as follows: 8=350ci, 190hp  
L=350ci, 230hp  
H=305ci, 180hp

**Suffix:** ZAK: 350ci, 190hp, at      ZBD: 350ci, 230hp, uu  
ZAM: 350ci, 190hp, mt      ZCA: 305ci, 180hp, at, ce  
ZBC: 350ci, 230hp, at

**Block:** 3970010: 350ci, 190hp, 230hp      4715111: 305ci, 180hp

**Head:** 462624: 350ci, 190hp, 230hp      14014416: 305ci, 180hp

**Carb:** Rochester Q-jet #17080204: 350ci, 190hp, at  
Rochester Q-jet #17080207: 350ci, 190hp, mt  
Rochester Q-jet #17080228: 350ci, 230hp, at  
Rochester Q-jet #17080504, 17080517: 305ci, 180hp, at, ce

**Distributor:** 1103287: 350ci, 190hp, mt      1103368: 305ci, 180hp, at, ce  
1103352: 350ci, 190hp      1103435: 350ci, 230hp, at  
1103353: 350ci, 190hp, at

**Alternator:** 1101041, 1101075, 1101085, 1101088, 1103122

**Abbreviations:** at=automatic transmission, ce=california emissions, ci=cubic inch, hp=horsepower, mt>manual transmission, uu=uncertain usage.

## 1980 FACTS

- For the first time since 1974, two engine displacements were available in Corvettes, but not optional. Because of tightened California emission restrictions, Chevrolet did not certify its 350 cubic-inch engines there in 1980. California Corvette buyers were required to purchase a 305ci engine, the RPO LG4, with a \$50 credit. This was a standard passenger car engine, built at Chevrolet's Tonawanda, New York, engine plant. In Corvettes, it could be combined only with automatic transmissions.
- The 4-speed manual transmission was not available with the optional L82 engine, with the possible exception of a few early production builds.
- The 1980 model featured new front and rear bumper "caps" with integral spoilers. Radiator air flow increased by nearly fifty-percent. The integrated spoilers improved the drag coefficient from .503 to .443 compared to the 1979 model equipped with optional, non-integrated spoilers.
- The crossed flag emblems for 1980 were a new, more elongated design.
- The speedometers for 1980 Corvettes read to a maximum of 85 mph, a new federal requirement. These were phased in during 1979 production.
- The three behind-seat storage compartments were changed to two in the 1980 model. The battery remained in its own compartment behind the driver, but the center and passenger-side compartments were combined with one access door.
- After several years of weight increases, the Corvette was lighter in 1980 as engineers trimmed weight by using lower density roof panels, reducing the thickness of hood and outer doors, and using aluminum for the differential housing and crossmember. For the base L48 engine, the L82's aluminum intake manifold became standard.
- The California RPO LG4 305ci engine included stainless-steel tubular exhaust headers with an oxygen sensor in a "closed loop" system. Despite its lower displacement and more restrictive emissions equipment, the Corvette application of this engine developed 180hp, just 10hp less than the 350ci, L48 base engine for other states.



## 1980 OPTIONS

RPO#	DESCRIPTION	QTY	RETAIL \$
1YZ87	Base Corvette Sport Coupe .....	40,614	\$13,140.24
AU3	Power Door Locks .....	32,692	140.00
CC1	Removable Glass Roof Panels .....	19,695	391.00
C49	Rear Window Defogger .....	36,589	109.00
FE7	Gymkhana Suspension .....	9,907	55.00
F51	Heavy Duty Shock Absorbers .....	1,695	35.00
K30	Cruise Control .....	30,821	123.00
LG4	305ci, 180hp Engine (required in California) .....	3,221	-50.00
L82	350ci, 230hp Engine .....	5,069	595.00
MM4	4-Speed Manual Transmission .....	5,726	0.00
MX1	Automatic Transmission .....	34,838	0.00
N90	Aluminum Wheels (4) .....	34,128	407.00
QGB	White Letter SBR Tires. P225/70R15 .....	26,208	62.00
QXH	White Letter SBR Tires. P255/60R15 .....	13,140	426.16
UA1	Heavy Duty Battery .....	1,337	22.00
U58	AM-FM Radio, stereo .....	6,138	46.00
UM2	AM-FM Radio, stereo with 8-track .....	15,708	155.00
UN3	AM-FM Radio, stereo with cassette .....	15,148	168.00
UP6	AM-FM Radio, stereo with CB .....	2,434	391.00
U75	Power Antenna .....	32,863	56.00
UL5	Radio Delete .....	201	-126.00
U81	Dual Rear Speakers .....	36,650	52.00
V54	Roof Panel Carrier .....	3,755	125.00
YF5	California Emission Certification .....	3,221	250.00
ZN1	Trailer Package .....	796	105.00

• A 350ci, 190hp, 350ci (180hp, 305ci in California for \$50 credit), 4-speed manual transmission or automatic transmission, T-tops, and leather/vinyl or cloth/vinyl interior trim were included in the base price.

• The Corvette's base price increased four times during 1980, increasing from \$13,140.24 to \$14,345.24. Option prices were not affected.

• RPO A31 power windows, RPO C60 air conditioning, and RPO N37 tilt-telescopic steering column, all optional for part of 1979, were included in the 1980's base price.

• RPO C49 rear window defogger included UA1 heavy-duty battery.

• RPO LG4 305ci, 180hp engine was required for California and not available elsewhere. It was not available with manual transmission.

• RPO V54 roof panel carrier mounted to the rear deck for external transport of removable roof panels. It was new for 1980.

• RPO ZN1 trailer package included heavy-duty radiator, not available as a separate option, and RPO FE7 gymkhana suspension.

## 1980 COLORS

CODE	EXTERIOR	QTY	WHEELS	INTERIORS
10	White .....	7,780	Silver	Bk-CI-Db-Ds-O-R
13	Silver .....	4,341	Silver	Bk-CI-Db-O-R
19	Black .....	7,250	Silver	Bk-Ds-O-R
28	Dark Blue .....	4,135	Silver	Bk-Db-Ds-O-R
47	Dark Brown .....	2,300	Silver	Bk-Ds-O
52	Yellow .....	2,077	Silver	Bk-O
58	Dark Green .....	844	Silver	Bk-Ds-O
59	Frost Beige .....	3,070	Silver	Bk-CI-Db-Ds-R
76	Dark Claret .....	3,451	Silver	Bk-CI-Ds-O
83	Red .....	5,714	Silver	Bk-Ds-O-R

• Suggested interiors shown. Additional combinations were possible.

• Records indicate no 1980 Corvettes had primer only.

• Code 492 for green leather interior was released, but cancelled early.

**Interior Codes:** 12C=O/C, 122=O/L, 192=Bk/L, 29C=Db/C, 292=Db/L, 59C=Ds/C, 592=Ds/L, 722=R/L, 79C=CL/C, 792=CL/L.

**Abbreviations:** Bk=Black, C=Cloth, CL=Claret, Db=Dark Blue, Ds=Doeskin, L=Leather, O=Oyster, R=Red.

.

# The Corvette Black Book

1953-1993

October 1992

Published by

Michael Bruce Associates, Inc.

Michael Antonick, President

Post Office Box 396

Powell, Ohio 43065



## CONTENTS

Glossary .....	4	1965 Corvette .....	44	1981 Corvette .....	76
Instructions .....	6	1966 Corvette .....	46	1982 Corvette .....	78
Statistics .....	12	1967 Corvette .....	48	1984 Corvette .....	80
Chronology .....	14	1968 Corvette .....	50	1985 Corvette .....	82
1953 Corvette .....	20	1969 Corvette .....	52	1986 Corvette .....	84
1954 Corvette .....	22	1970 Corvette .....	54	1987 Corvette .....	86
1955 Corvette .....	24	1971 Corvette .....	56	1988 Corvette .....	88
1956 Corvette .....	26	1972 Corvette .....	58	1989 Corvette .....	90
1957 Corvette .....	28	1973 Corvette .....	60	1990 Corvette .....	92
1958 Corvette .....	30	1974 Corvette .....	62	1991 Corvette .....	94
1959 Corvette .....	32	1975 Corvette .....	64	1992 Corvette .....	96
1960 Corvette .....	34	1976 Corvette .....	66	1993 Corvette .....	98
1961 Corvette .....	36	1977 Corvette .....	68	Notes .....	100
1962 Corvette .....	38	1978 Corvette .....	70	Photos/Specs .....	104
1963 Corvette .....	40	1979 Corvette .....	72	Literature .....	124
1964 Corvette .....	42	1980 Corvette .....	74	Coupons .....	127

© Michael Bruce Associates, Inc., 1978, 1980, 1983, 1985, 1988, 1991, 1992. All rights reserved under Pan American and Universal Copyright Conventions by Michael Bruce Associates, Inc. Reproduction without permission is prohibited. Because of the possibility of errors, exceptions, or other reasons for inaccuracy, the publisher and author disclaim responsibility for the accuracy of any or all information presented in this publication.

Michael Bruce Associates, Inc. acknowledges with appreciation the following enthusiasts who contributed their expertise to this and previous editions of the *Corvette Black Book*: Noland Adams, Dan Aldridge, John Amgwer, Pat Baker, Jane Bartheime, Michele Boling, Ken Brooks, Barry Brown, David Burroughs, Steve Dangrenmond, Dr. M. F. Dobbins, Bob Eckles, the late Sam Folz, John Hibbert, Mike Hunt, Alan Kaplan, Paul Kitchen, Gary Konner, Ralph Kramer and staff, Jim Krugloff, Gary Lisk, Bill Locke, Bob Ojowski, Bob McDorman, Chip Miller, Bill Mock, Brian Pearce, John Poloney, Bill Rhodes, Jeffrey Smith, Mark & Dixie Smith, Lou Vitale, Jerry Wadsworth, Jerry Weichers and Don Williams. Thanks also to Callaway Engineering, to Mercury-Marine, and to the Chevrolet Motor Division of General Motors Corporation.

**Notice:** *The Corvette Black Book* and its publisher, Michael Bruce Associates, Inc. have no relationship or connection whatever with Hearst Business Media Corporation, its parent or affiliated corporations, or the *Black Book* published by National Auto Research Division of Hearst Business Media Corporation.

Michael Bruce Associates, Inc. and the *Corvette Black Book* are not associated with or sponsored by General Motors or its Chevrolet Motor Division.

**Cover:** Photo and design by Mike Antonick. 1963 Corvette owned by Bill Munzer; restored by Bill Munzer and Don Williams.

Printed and bound in the United States of America

ISBN: 0-933534-35-3



## BLACK BOOK ORDER FORM

Send \_\_\_\_\_ copies of the

**Corvette Black Book 1953-1993**

@ \$11.95 each \$ \_\_\_\_\_

Ohio residents add .72 sales tax \_\_\_\_\_

Postage/hard shipping container 3.00 \_\_\_\_\_

Check or money order enclosed \$ \_\_\_\_\_

Name \_\_\_\_\_

Street \_\_\_\_\_

City \_\_\_\_\_ State \_\_\_\_\_ Zip \_\_\_\_\_

Mail Order To: **Michael Bruce Associates, Inc.**  
**Post Office Box 396**  
**Powell, Ohio 43065**



## BLACK BOOK ORDER FORM

Send \_\_\_\_\_ copies of the

**Corvette Black Book 1953-1993**

@ \$11.95 each \$ \_\_\_\_\_

Ohio residents add .72 sales tax \_\_\_\_\_

Postage/hard shipping container 3.00 \_\_\_\_\_

Check or money order enclosed \$ \_\_\_\_\_

Name \_\_\_\_\_

Street \_\_\_\_\_

City \_\_\_\_\_ State \_\_\_\_\_ Zip \_\_\_\_\_

Mail Order To: **Michael Bruce Associates, Inc.**  
**Post Office Box 396**  
**Powell, Ohio 43065**





## 1980 CORVETTE

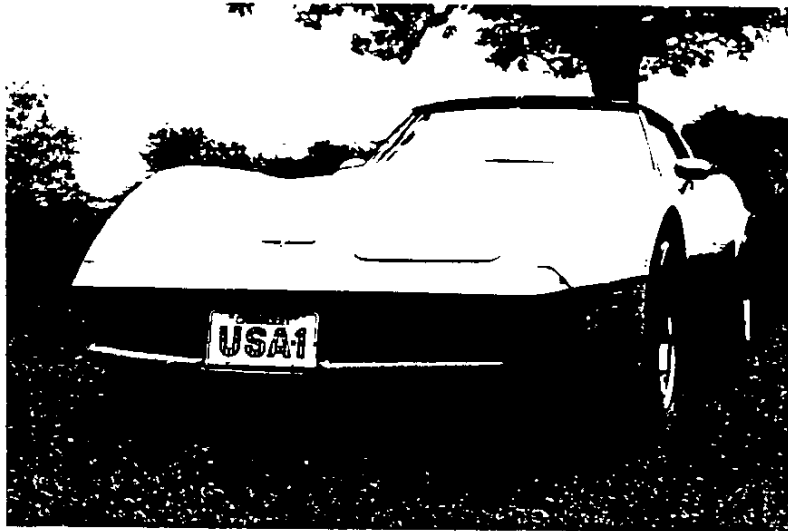

*Author photo*

**1980 Corvette**  
**Length:** 185.3 inches  
**Width:** 69.0 inches  
**Height:** 48.0 inches  
**Curb Weight:** 3,336 pounds  
**Wheelbase:** 98 inches  
**Tire Size:** P225/70R15  
**Track:** 58.7 inches front, 59.5 inches rear



## 1980 CORVETTE.

How many other cars can you name at a single glance? That should tell you something about the continuing uniqueness of Corvette. It could very well be the most recognizable car on the road today. It has a host of imitators. But none of them catch your eye with such striking authority. Because Corvette remains what they can only aspire to be. A legend. Still the only true American production sports car.

Since 1953, Corvette has claimed a special place in the hearts of those who love cars. It has captured that fine line between dreams and reality.

Corvette for 1980. The legend lives on.

As you can see, Corvette engineers have been successful once again in refining this legendary classic.

The new, aerodynamically designed front bumper cover now features an integral air dam and deeply recessed grille and parking lights. And functional air exhaust louvers were added to the front fender air vents. They're black in keeping with many other styling accents.

Other exterior highlights include a new hood with a lower profile. New rear bumper cover with integral rear spoiler. New flag emblems. New rear lights. And cornering lights, new to Corvette as well as being standard, are fully automatic. The lights are illuminated by the turn signal when the headlights are on . . . and are turned off when the signal is cancelled.

Inside there's a new rich, ribbed pattern cloth interior. And for the driver, a standard sliding sun shield to help cut down on side sun for added comfort.

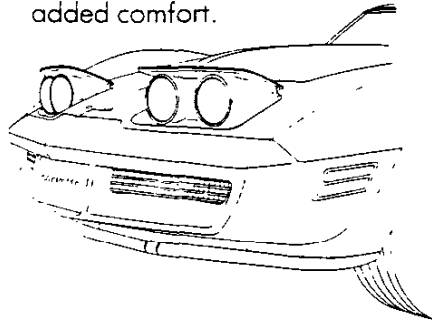

And there's good news for those who like their Corvettes luxury equipped. For 1980, the Corvette comes complete with air conditioning, dual Sport mirrors, power windows, Tilt-Telescopic steering wheel, and a convenience group which consists of comforting

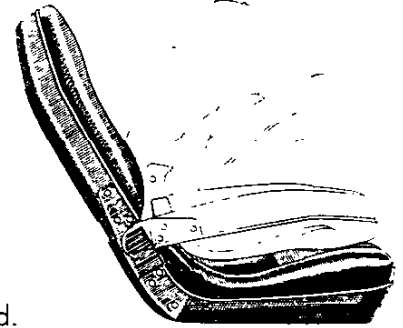

items like time-delay dome and courtesy lights and intermittent windshield wipers. (Check below for a more complete listing of standard 1980 Corvette features.)

But don't get the idea that the Corvette is dedicated only to comfort and convenience. It's still one great sports machine. In fact, an extensive weight reduction program has lowered the 1980 Corvette's weight by hundreds of pounds compared to last year. With a 5.7 Liter 4-Bbl. V8 still the standard engine (5.0 Liter in California). Result? Better weight efficiency.

For 1980, Corvette remains one trim machine — with enough comfort and convenience features to add pleasure to the sport. Its list of standards speaks for itself.

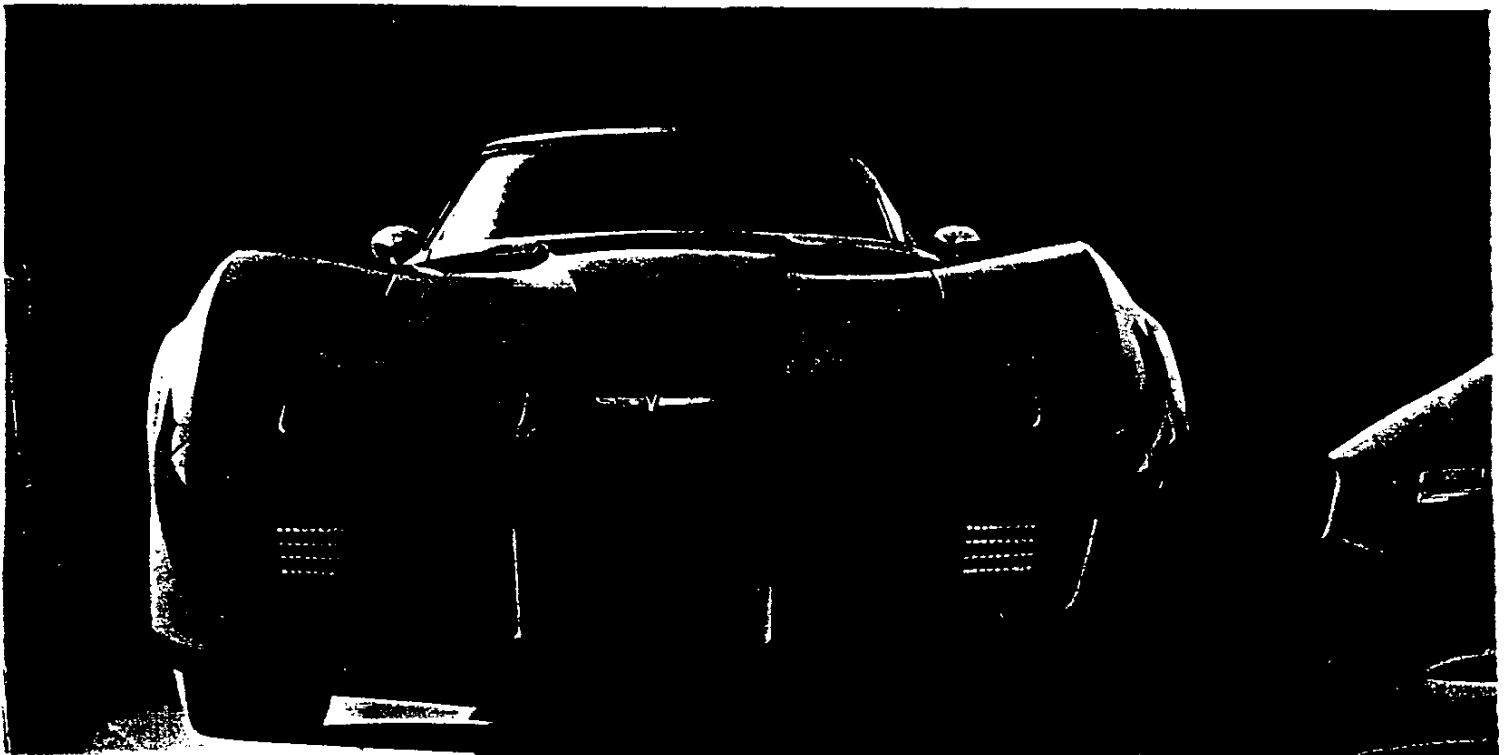



## NEW STANDARDS FOR 1980

Air conditioning • Cornering lights  
• Power windows • Tilt-Telescopic steering wheel • Dual, remote-control Sport mirrors  
• Convenience group (includes time-delay dome and courtesy lights, headlight warning buzzer, underhood light, low fuel warning light, color-keyed floor mats, intermittent windshield wipers and a passenger-side illuminated visor vanity mirror).

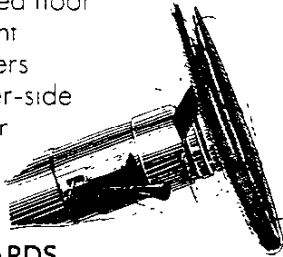

## MORE STANDARDS

5.7 Liter (5.0 Liter in California) 4-Bbl. V8 engine • Automatic transmission or Four-Speed fully synchronized transmission (except California)  
• AM/FM radio • High Energy Ignition system • Steel-belted radial ply tires  
• Power disc brakes at all four wheels  
• Limited slip rear axle • Fully independent four-wheel suspension system • Power steering • Exhaust valve rotators for even wear • Delco Freedom battery never needs refilling. Sealed side terminals help prevent corrosion buildup • Delcotron generator with built-in solid-state regulator • Hydraulic valve lifters  
• Large-diameter front

stabilizer bar • Wide 15" x 8" wheels  
• Removable roof panels • Tinted glass in all windows • Heavy-gage frame structure with corrosion-resistant coating • Energy-absorbing honeycomb cushion front bumper system • Energy-absorbing rear bumper system with twin hydraulic cylinders • Hide-A-Way windshield wipers with integral washers in wiper arms • Power-operated retractable headlights • High-rise front fenders with functional louvers • Corrosion-resistant steel-reinforced fiberglass body with a steel partial-frame underbody • Built-in anti-theft audio alarm system control switch integral with driver's door lock • Special

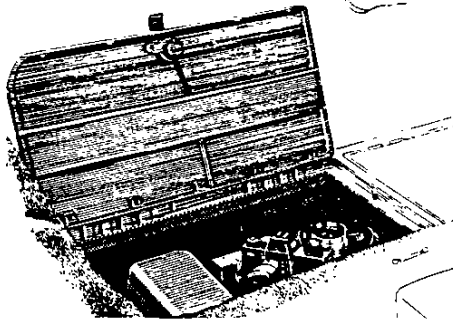

Custom Interior with choice of cloth/leather or all-leather seating surfaces  
• Day/night inside rearview mirror  
• Sport-styled 3-spoke steering wheel  
• Aircraft-style center console  
• Tachometer (7000 rpm)

• Electric clock • Ammeter, oil pressure, fuel and temperature gages • Separate trip odometer • Console-mounted parking brake control • Cut-pile carpeting • Color-keyed seat belts  
• Folding seat back latches • Roof courtesy light with automatic door switches • Underfloor stowage compartment.

## A WORD ABOUT THIS CATALOG:

*We have tried to make this catalog as comprehensive and factual as possible. And we hope you find it helpful. However, since the time of printing, some of the information you'll find here may have been updated. Also, some of the equipment shown or described throughout this catalog is available at extra cost. Your dealer has details and, before ordering, you should ask him to bring you up to date.*

*The right is reserved to make changes at any time, without notice, in prices, colors, materials, equipment, specifications and models, and to discontinue models. Check with your Chevrolet dealer for complete information.*

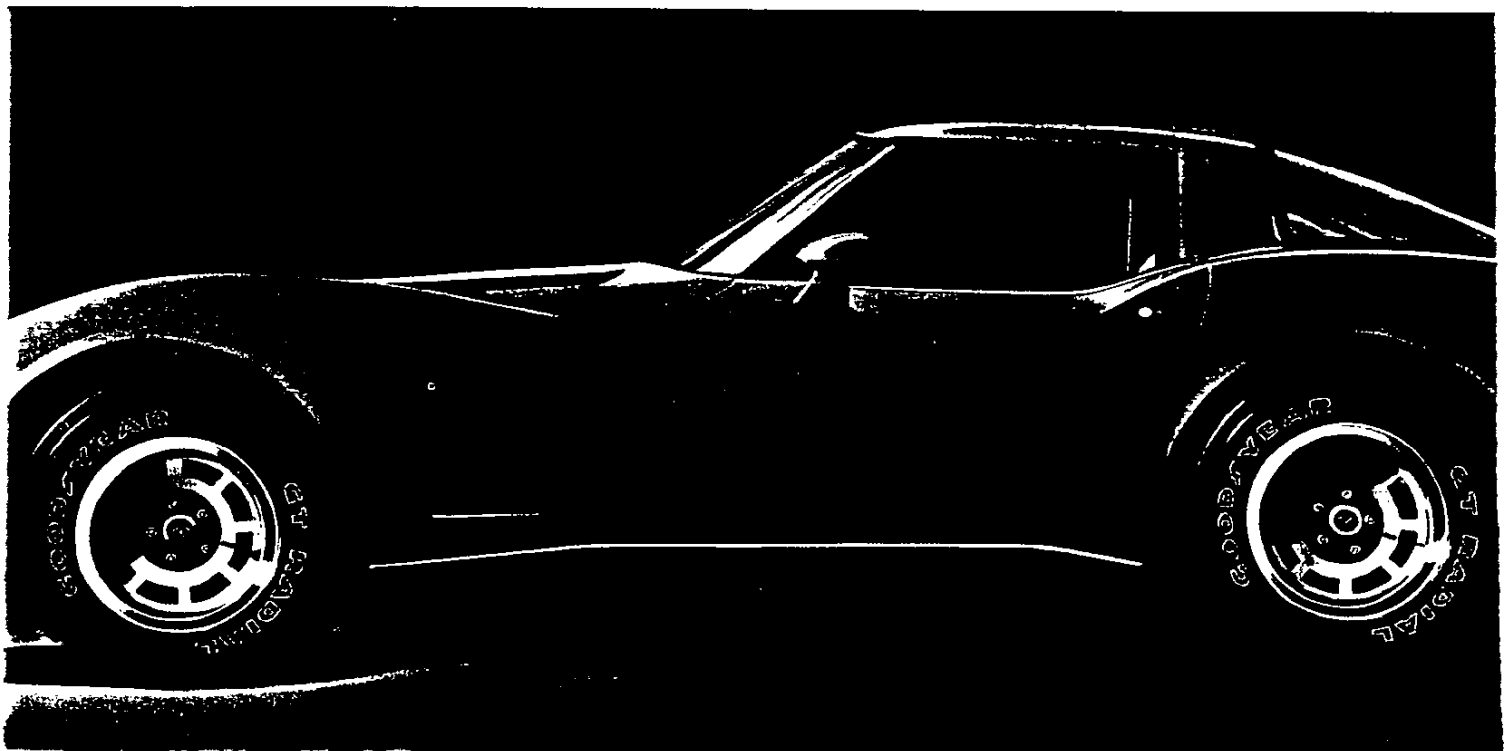



### A WORD ABOUT ENGINES

Chevroleets are equipped with GM-built engines produced by various divisions. Please refer to the Corvette Power Teams Chart or see your dealer for details.

#### Engine Selections:

##### Standard 5.7 Liter V8

This modern, large-bore engine of short-stroke design with rugged cast-iron heads, manifolds and cylinder block is very willing and able on the highway while showing impressive low-speed operation for around-town cruising. Also impressive are its refinements over '79 models: new exhaust pipes for improved flow and lighter weight metals used on selected components.

##### Available Special 5.7 Liter L82 V8

This performer features a higher lift cam than the standard Corvette V8, has special heads with impact-extruded pistons, a forged steel crankshaft, with each main bearing cap secured by four bolts, plus finned, aluminum rocker arm covers to help dissipate heat.

### 1980 CORVETTE POWER TEAMS

Engine	Ordering Code	Displacement (Cu. In.)	Engine Availability	4-Speed	
				Manual (1)	Automatic (1)
<b>ALL STATES EXCEPT CALIFORNIA</b>					
5.7 Liter 4-Bbl. V8 (A)	L48	350	Std.	Std.	(2)
5.7 Liter 4-Bbl. V8 (A)	L82	350	EC	NA	Std.
<b>CALIFORNIA ONLY (with California Emission Requirements)</b>					
5.0 Liter 4-Bbl. V8 (A)	LG4	305	Std.	NA	Std.

Std. - Standard. NA - Not Available. EC - Available at extra cost.

(1) With console-mounted shift control. (2) Available in place of standard 4-Speed manual transmission at no extra cost. (A) Produced by GM - Chevrolet Motor Division.

#### Long Recommended Service Intervals (Under normal operating conditions)

Engine Oil	12 months or 7500 miles
Oil Filter	Every 12 months or first 7500 miles; every 15,000 miles thereafter.
Spark Plugs	Up to 30,000 miles
Chassis Lubrication	12 months or 7500 miles
Automatic Transmission Fluid Change	Every 100,000 miles

#### DIMENSIONS (Inches)

##### Exterior

Wheelbase	98.0
Length (overall)	185.3
Width (overall)	69.0
Height (loaded)	48.0
Tread - Front	58.7
Tread - Rear	59.5

##### Interior

Head Room -	36.2
Leg Room -	42.1
Hip Room -	49.9
Shoulder Room -	47.5
Usable Luggage Capacity (cu. ft.)	8.4

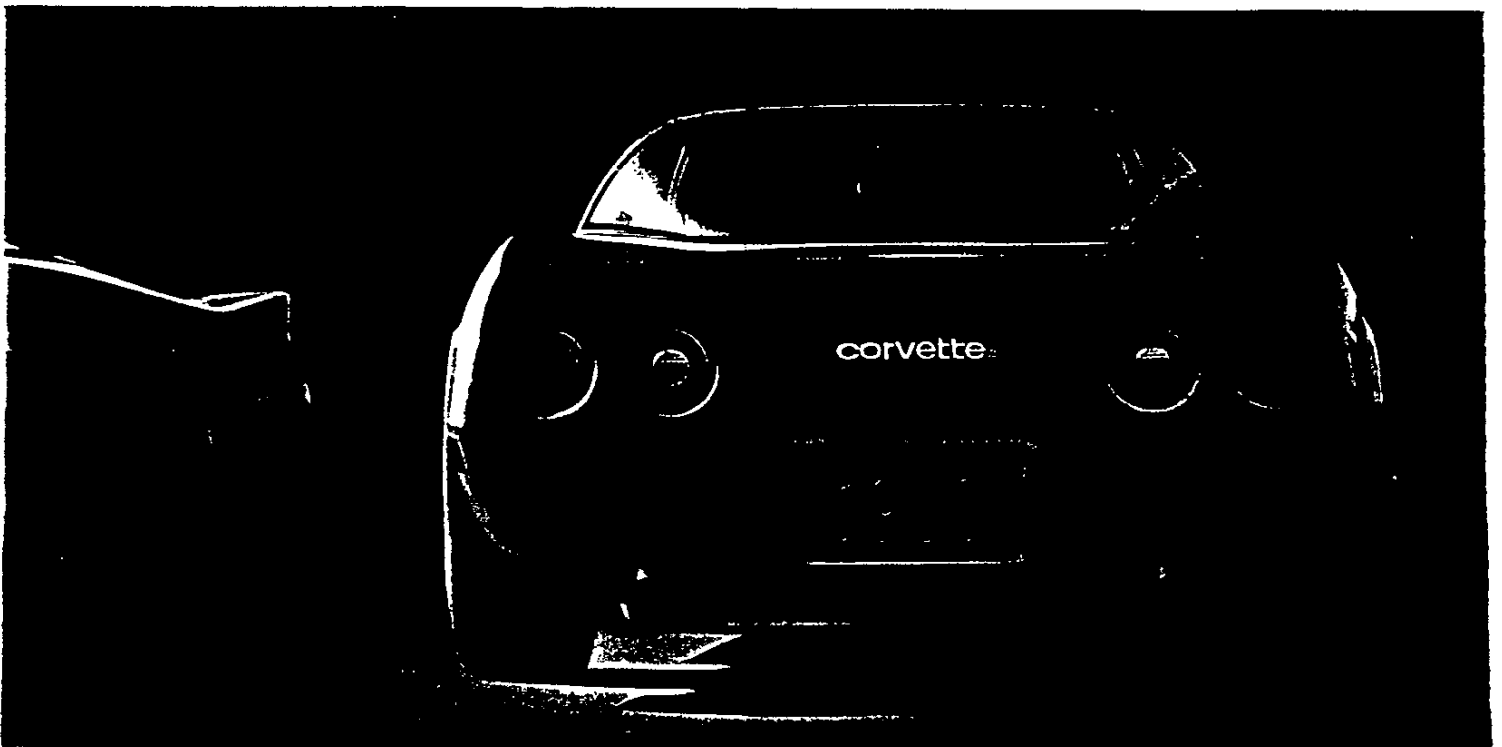





-

2

2

2



## 1980 CORVETTE CONTINUED.

If you care to add options to your Corvette, consider these: AM/FM stereo radios with either stereo tape or CB; removable glass roof panels to help give you that open-air feeling (removable fiberglass roof panels are standard); a new handy roof panel carrier; power door locks; new aluminum wheels; and Gymkhana suspension equipment which includes larger diameter rear stabilizer bar and bushing, higher rate springs and special shock

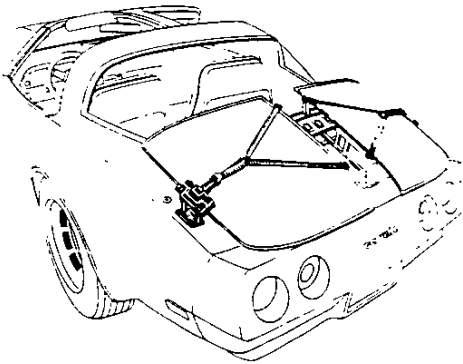

absorbers. Other options are available. Check them over when you custom build your own Corvette.

And don't forget you have a choice of bucket seat interiors: cloth/leather or all-leather seating surfaces.

While you're in the driver's seat,

you'll be aware of an imposing array of instrumentation in front of you and off to your right. Included is a speedometer with trip odometer, tachometer, coolant temperature gage, oil pressure gage, voltmeter, fuel gage and clock. Your Corvette keeps you well informed. Also at hand are convenient controls for the radio, power windows and air conditioning.

More convenience is provided by the passenger seat which folds virtually flat on the seat cushion for easy access to the concealed rear storage area. A great spot to tuck valuables out of sight.

One thing you won't tuck out of sight is Corvette's sophisticated sporty looks. Its profile will turn heads and get envious looks. That's Corvette... America's legendary dream machine in action.

### Exterior Colors:

Dark Blue (Metallic), Yellow, Dark Claret (Metallic) and Red. Other colors: Dark Brown (Metallic), Classic White, Silver, Black, Dark Green (Metallic) and Light Beige.

### Interior Choices:

Cloth and leather seats are available in beige, blue, claret or

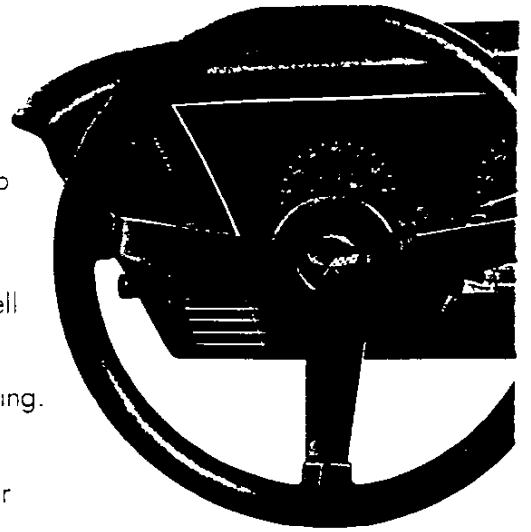

oyster. Leather seats in the same colors plus black and red.

### SAFETY FEATURES

#### Occupant protection

- Two front combination seat and inertia reel shoulder belts with push-button buckles for driver (with reminder light and buzzer) and passenger
- Energy-absorbing steering column
- Passenger guard door locks
- Safety door latches and stamped steel hinges
- Folding seat back latches
- Energy-absorbing padded instrument panel
- Laminated windshield
- Safety armrests.

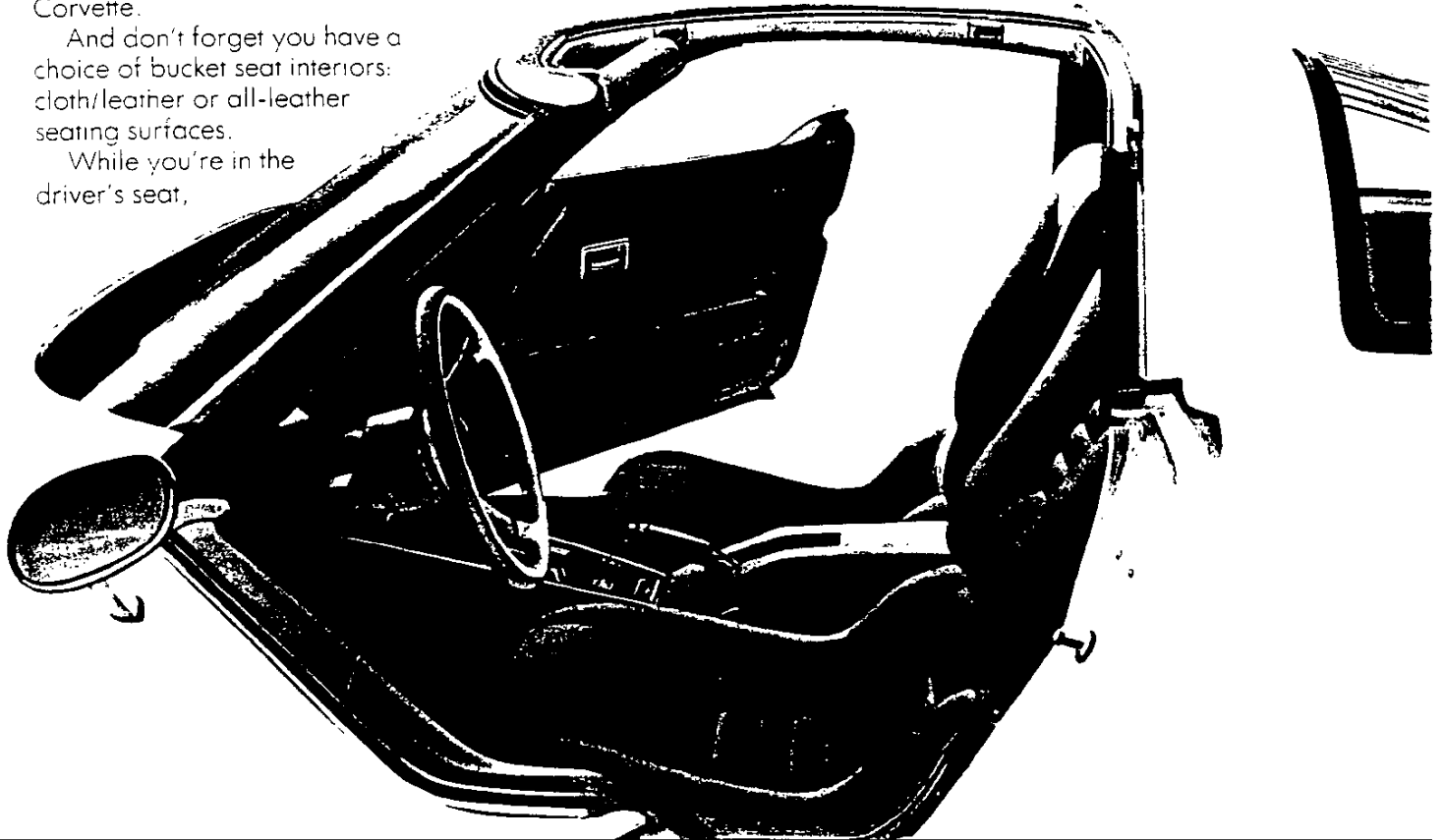



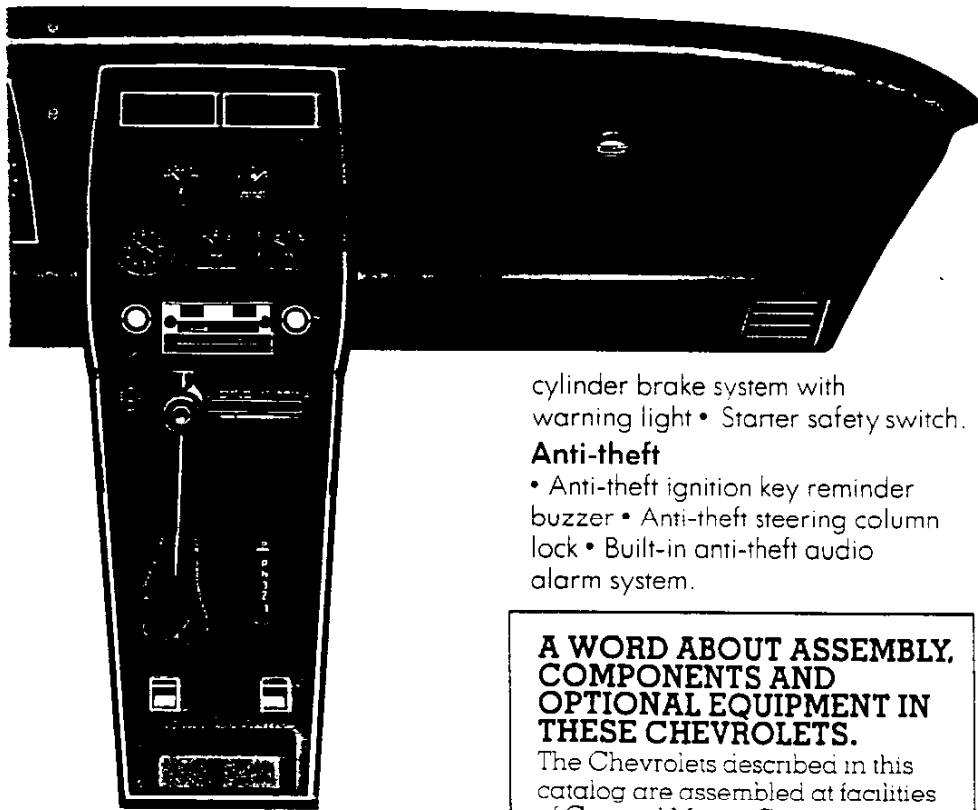

#### Accident avoidance

- Side marker lights and reflectors
- Parking lamps that illuminate with headlamps • Four-way hazard warning flasher • Backup lights
- Lane change feature in direction signal control • Windshield defrosters, washer and dual-speed wipers • Wideview inside mirror vinyl-edged, shatter-resistant glass and deflecting support • Dual, remote-control outside rearview mirrors • Dual master

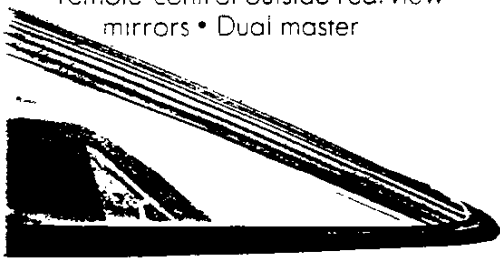

cylinder brake system with warning light • Starter safety switch.

#### Anti-theft

- Anti-theft ignition key reminder buzzer • Anti-theft steering column lock • Built-in anti-theft audio alarm system.

#### A WORD ABOUT ASSEMBLY, COMPONENTS AND OPTIONAL EQUIPMENT IN THESE CHEVROLETS.

The Chevrolets described in this catalog are assembled at facilities of General Motors Corporation operated by the GM Assembly Division. These vehicles incorporate thousands of different components produced by various divisions of General Motors and by various suppliers to General Motors. From time to time during the manufacturing process, it may be necessary, in order to meet public demand for particular vehicles or equipment, or to meet federally mandated emissions, safety and fuel economy requirements, or for other reasons, to produce Chevrolet products with different components or differently sourced components than initially scheduled. All such components have been approved for use in Chevrolet products and will provide the quality performance associated with the Chevrolet name.

With respect to extra cost optional equipment, make certain you specify the type of equipment you desire on your vehicle when ordering it from your dealer. Some options may be unavailable when your car is built. Your dealer receives advice regarding current availability of options. You may ask the dealer for this information. GM also requests the dealer to advise you if an option you ordered is unavailable. We suggest you verify that your car includes the optional equipment you ordered or, if there are changes, that they are acceptable to you.

## CUSTOM BUILD YOUR CORVETTE.

(See your dealer for current ordering information and specific model option availability.)

- Exterior color
- Interior color  Upholstery

#### ENGINES

(See Power Teams Chart for details on engine and transmission availability.)

- 5.7 Liter 4-Bbl. V8 (350 Cu. In.) (Std.)\*
- 5.0 Liter 4-Bbl. V8 (305 Cu. In.) (Std. in California)
- 5.7 Liter 4-Bbl. L82 V8 (350 Cu. In.) (Available)\*

#### TRANSMISSION

- 4-Speed manual\*  Automatic

#### AVAILABLE OPTIONS

- Removable tinted glass roof panels.
- Automatic speed control (automatic transmission required).
- Electric rear window defogger.
- Power door locks.

#### SOUND EQUIPMENT

- AM/FM stereo/Citizens Band radio with tri-band power antenna.
- AM/FM stereo radio.
- AM/FM stereo radio with 8-track stereo tape.
- AM/FM stereo radio with stereo cassette tape.
- Power antenna.
- Dual rear speakers.

#### TIRES

- P225/70R-15 steel-belted radial ply white-lettered tires.
- P255/60R-15 steel-belted radial ply white-lettered tires.

#### MISCELLANEOUS

- Aluminum wheels.
- Gymkhana suspension.
- Chassis equipment — trailering.
- Heavy-duty battery.
- Roof panel carrier.
- Heavy-duty shock absorbers.

\*Not available in California.

**Continuous  
Protection  
Plan**



#### The GM Continuous Protection Plan.

It offers service protection in addition to that provided by GM's new vehicle limited warranty. Ask your dealer about it. Coverage is limited to U.S.A. and Canada for 1980 model year.



Litho in U.S.A.



July, 1979 3906



# 1980 CORVETTE

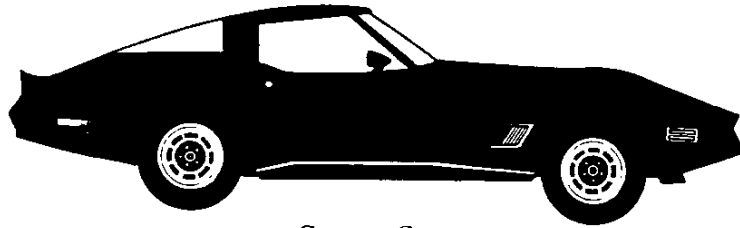

Corvette Coupe

Corvette	Model No.
Coupe .....	1YZ87

## Index

Corvette Value Features for 1980 .....	2-4	Available Options .....	9
Corvette Coupe .....	5	Power Teams .....	10
Interior Features .....	6	Body/Chassis Features .....	11
Instrument Panel Features .....	7	Dimensions/Specifications .....	12
Color and Trim Combinations .....	7	Color & Trim Selections .....	13-15
Equipment Summary .....	8		

*Also see Value Features and Option Features sections for additional details.*

See Dealer Order Guide for latest available information.

Corvette 1

# CORVETTE VALUE FEATURES FOR 1980

New Features for 1980 shown in Bold Face

## ENGINE/CHASSIS

- 5.7 Liter 4-Bbl. V8 engine *standard*: except in California. See Power Teams for availability
- Automatic transmission or four-speed fully synchronized transmission *standard*
- High Energy Ignition system *standard*
- Early Fuel Evaporation systems on all engines for quick warm-up
- Heavy-gage frame structure with corrosion-resistant coating
- Energy-absorbing honeycomb cushion front bumper system
- Energy-absorbing rear bumper system
- Power disc brakes at all four wheels *standard*
- Limited slip differential *standard*
- Fully independent four-wheel suspension system *standard*
- Power steering *standard*
- Temperature-controlled engine radiator fan
- Exhaust valve rotators on all engines
- Delco Freedom battery that never needs refilling *standard*. Sealed side terminals help prevent corrosion buildup
- Delcotron generator with built-in solid-state regulator *standard*
- Hydraulic valve lifters *standard*
- Large-diameter front stabilizer bar *standard*

- P225/70R-15 steel-belted radial ply blackwall tires *standard*
- Wide 15 x 8 wheels *standard*
- Long recommended service intervals for oil change, oil filter, spark plugs, chassis lubrication and automatic transmission fluid

## BODY/EXTERIOR

- **New front and rear bumper covers with integral spoilers**
- **New recessed grille and parking light styling**
- **New lower profile hood design**
- **Front cornering lights *standard***
- **Functional black-accented front fender louvers**
- **New taillight styling**
- Tinted glass in all windows *standard*
- **Dual remote control sport mirrors *standard***
- Concealed dual-speed electric windshield wipers with integral washers in wiper arms *standard*
- Power-operated retractable headlights *standard*
- High-rise front fenders with functional louvers
- Corrosion-resistant steel-reinforced fiberglass body with partial steel underbody
- Built-in anti-theft audio alarm system control switch integral with driver's door lock *standard*

## INTERIOR

- Choice of cloth and vinyl or

- leather and vinyl seat trim (cloth cushion and seat back panels) or leather and vinyl trim (leather cushion and seat back panels)
- **Air conditioning *standard***
- **Power windows *standard***
- **Tilt-Telescopic leather-wrapped steering wheel *standard***
- Day/night inside rearview mirror *standard*
- Aircraft-style center console *standard*
- Tachometer (7,000 rpm) *standard*
- AM/FM radio *standard* (may be deleted for credit)
- Electric clock *standard*
- Voltmeter, oil pressure, fuel and temperature gages *standard*
- Separate trip odometer *standard*
- Console-mounted parking brake control *standard*
- Cut-pile carpeting *standard*
- Swiveling sun visors *standard*
- Color-keyed seat and shoulder belts *standard*
- Automatic seat back latches
- Roof courtesy light with automatic door switches *standard*
- Rear compartment stowage with security shade *standard*

## NEW OPTION

- Roof Panel Carrier ..... RPO V54

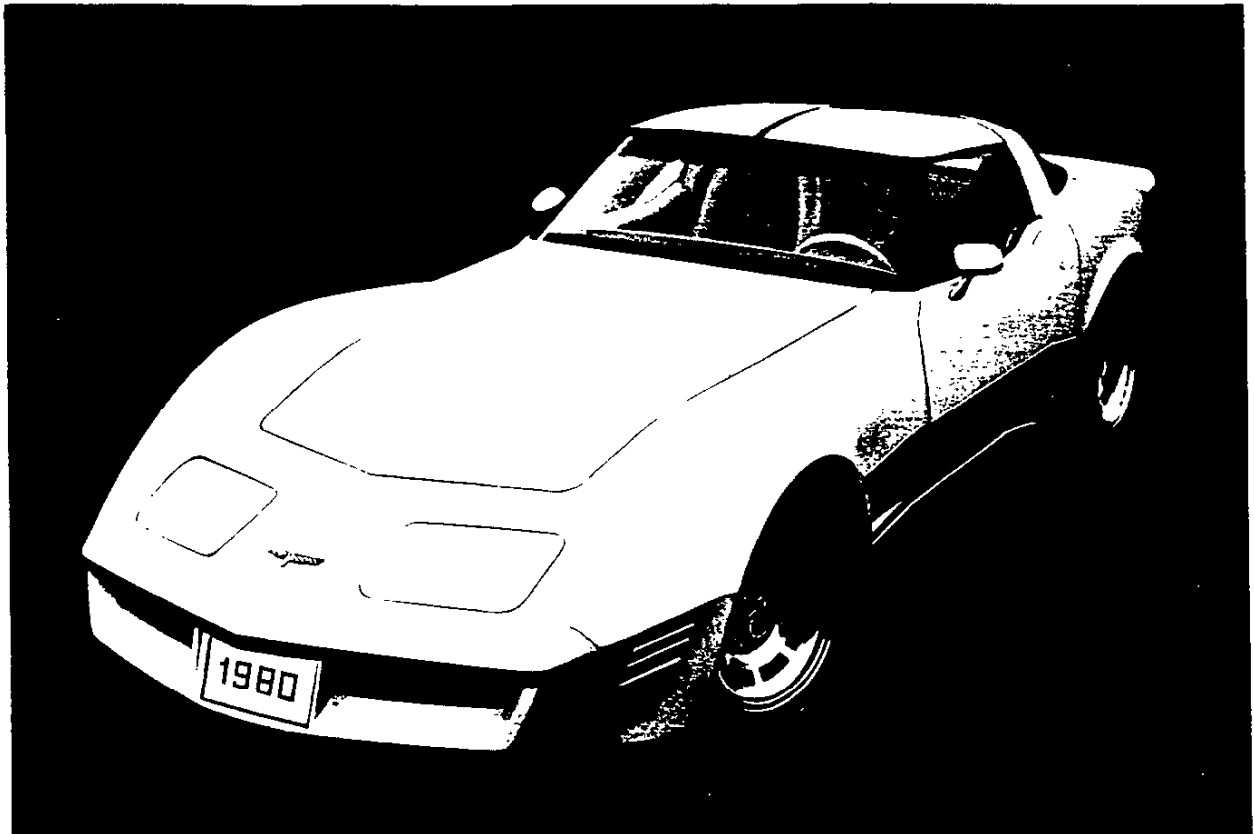

New Corvette Front Styling

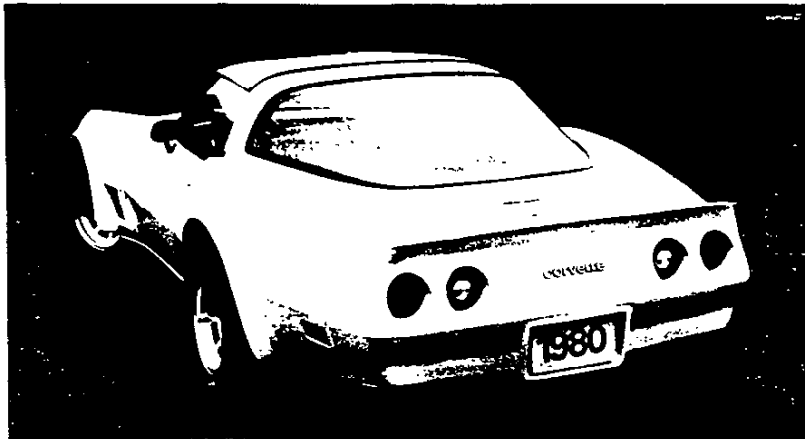

New Corvette Rear Styling



Available AM/FM Stereo/Citizens Band Radio



Available Removable Glass Roof Panels



Power Window Controls on Console  
*Standard*

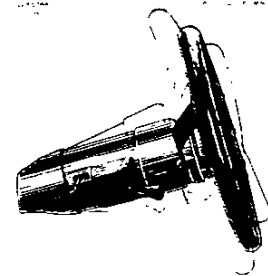

Tilt-Telescopic Steering Wheel *Standard*



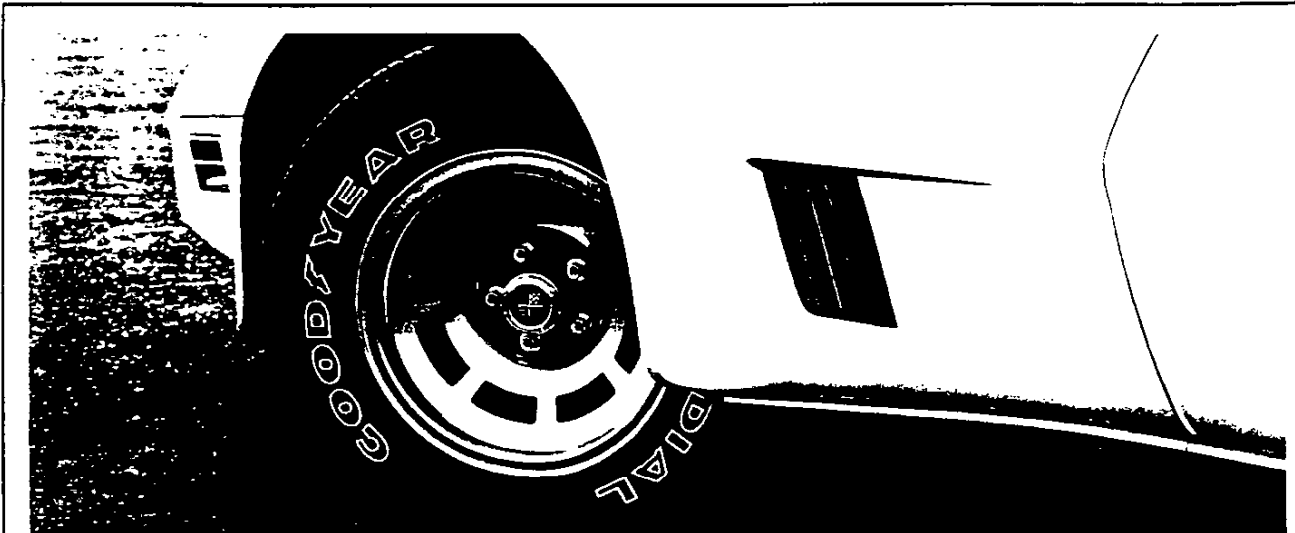

Available Aluminum Wheels and White-Lettered Radial Ply Tires

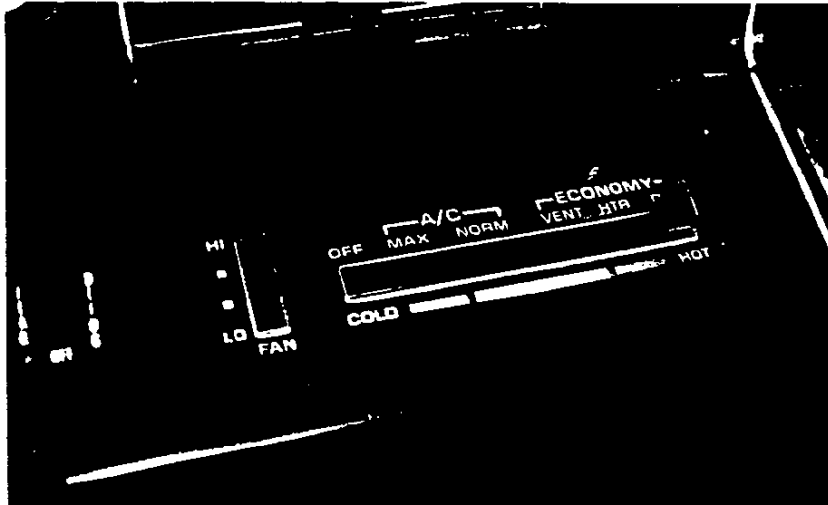

Air Conditioning Controls on Console *Standard*

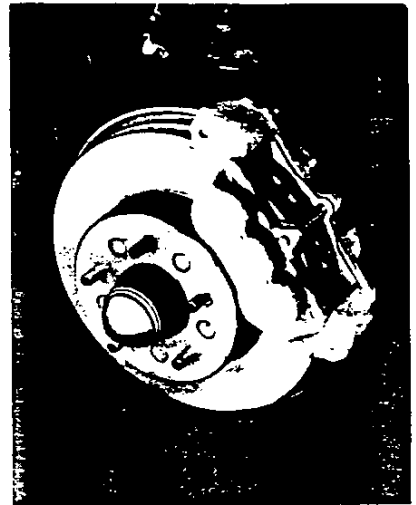

Power Disc Brakes at all Four Wheels *Standard*



Available Roof Panel Carrier



Built-In Anti-Theft Audio Alarm System *Standard*

# POWER TRAINS

POWER TEAM COMBINATIONS . . . . .	2
POWER TEAM MULTIPLICATION FACTORS . . . . .	2
ENGINE DATA AND RATINGS . . . . .	3
ENGINE SPEED AND PISTON TRAVEL . . . . .	3
VEHICLE PERFORMANCE FACTORS . . . . .	4
PRINCIPAL COMPONENTS . . . . .	5-9
FUEL SYSTEM . . . . .	10
EXHAUST SYSTEM . . . . .	10
EMISSION CONTROL EQUIPMENT . . . . .	11
LUBRICATION SYSTEM . . . . .	12
COOLING SYSTEM . . . . .	13
ELECTRICAL SYSTEM . . . . .	14
CLUTCH . . . . .	15
FOUR SPEED TRANSMISSION . . . . .	15
THREE-SPEED AUTOMATIC TRANSMISSION . . . . .	16

# POWER TEAM COMBINATIONS

ENGINE	TRANSMISSION	MODEL APPLICATION	REAR AXLE RATIO*		I.W. CLASS (lbs.)
			BASE	OPTION	
5.7 Liter V-8 (350 CID) L48 Base - All states exc. Calif.	4-Speed Manual (2.88 low)	Sport Coupe	3.07	-	3625
	3-Speed Auto '350c'		3.07	-	
5.7 Liter V-8 (350 CID) L82 Avail. - All states exc. Calif.	3-Speed Auto '350c'	Sport Coupe	3.07	-	3625
5.0 Liter V-8 (305 CID) LG4 Base - Calif. only	3-Speed Auto '350'	Sport Coupe	3.07	-	3625

\* Ring gear diameter - 8.50".

## MULTIPLICATION FACTORS

### WITH MANUAL TRANSMISSION

ENGINE	TRANSMISSION	TOTAL GEAR REDUCTION					AXLE RATIO
		1st	2nd	3rd	4th	Rev.	
5.7 Liter V-8 RPO L48	4-Speed	8.84	5.86	4.08	3.07	8.53	3.07

### WITH AUTOMATIC TRANSMISSION

ENGINE	TRANSMISSION	SELECTOR POSITION	TOTAL TORQUE MULTIPLICATION	AXLE RATIO
5.7 Liter V-8 RPO L48	3-Speed Auto '350c'	Drive	15.47:1 - 3.07:1	3.07
		Second	15.47:1 - 4.67:1	
		Low	15.47:1 - 7.74:1	
		Reverse	11.85:1 - 5.92:1	
5.7 Liter V-8 RPO L82	3-Speed Auto '350c'	Drive	15.47:1 - 3.07:1	3.07
		Second	15.47:1 - 4.67:1	
		Low	15.47:1 - 7.74:1	
		Reverse	11.85:1 - 5.92:1	
5.0 Liter V-8 RPO LG4	3-Speed Auto '350'	Drive	15.47:1 - 3.07:1	3.07
		Second	15.47:1 - 4.67:1	
		Low	15.47:1 - 7.74:1	
		Reverse	11.85:1 - 5.92:1	

# ENGINE DATA AND RATINGS

## GENERAL DATA

Engine Type		90° V - OHV		
Piston Displacement	Liters	5.0	5.7	
	In <sup>3</sup>	305	350	
Availability		RPO LG4	RPO L48	RPO L82
Number of Cylinders		8		
Bore and Stroke		3.736 x 3.48	4.00 x 3.48	
Compression Ratio		8.6:1	8.2:1	9.0:1
Taxable (SAE) Horsepower		44.7	51.2	
Firing Order		1-8-4-3-6-5-7-2		
Idling Speed	Manual (in Neutral)	- - -	700	
	Automatic (in Drive)	650	500	
Compression Press. @ Cranking Speed Engine Hot				
Power Plant Mounting		Two front and one rear, compression type		
Measurements	Fan to rear engine block	31.55	31.55	30.86
	Top A/C to bottom oil pan	29.60	28.52	29.42
	Exhaust manifold to generator	28.53		

## ADVERTISED ENGINE RATING

Engine Designation	Availability	Carburetor	Federal	Calif.	Net Brake HP @ RPM	Net Torque@ RPM (lb.ft.)
5.7 Liter V-8	RPO L48	4-Barrel	X	-	190 @ 4400	280 @ 2400
	RPO L82		X	-	230 @ 5200	275 @ 3600
5.0 Liter V-8	RPO LG4		-	X	180 @ 4200	255 @ 2000

## ENGINE SPEED AND PISTON TRAVEL

Engine	5.0 Liter V-8	5.7 Liter V-8		
Transmission	3-Speed Auto.	4-Speed Manual	3-Speed Auto.	
Rear Axle Ratio	3.07	3.07	3.07	
Tire Size	P225/70R15			
Crankshaft Revs./Mile	2333.2			
Crankshaft RPM @ 1 MPH	Low	98.0	112.0	98.0
	Second	59.1	74.3	59.1
	Third	38.9	51.7	38.9
	Fourth	-	38.9	-
	Reverse	75.5	108.1	75.5
Piston Travel (Feet/Mile)	1353.3	1353.3		

# VEHICLE PERFORMANCE FACTORS

ENGINE	5.7 Liter V-8 (350 CID) L48 190 HP	5.7 Liter V-8 (350 CID) L82 230 HP	5.0 Liter V-8 (305 CID) LG4 180 HP
MODEL	1YZ87	1YZ87	1YZ87

## 4-SPEED MANUAL TRANSMISSION

Performance Weight (pounds)		3633
Pounds/Net Horsepower	Federal	19.12
Pounds/Cu. In. Displacement		10.38
Net HP/Cu. In. Displacement	Federal	0.543
Power Displacement (cu.ft./mile)		236.3
Displacement Factor (cu.ft./ton mile)		130.1

## 3-SPEED AUTOMATIC TRANSMISSION

Performance Weight (pounds)		3658	3678	3654
Pounds/Net Horsepower	Federal	19.25	15.99	--
	Calif.	--	--	20.30
Pounds/Cu. In. Displacement		10.45	10.51	11.98
Net HP/Cu. In. Displacement	Federal	0.543	0.657	--
	Calif.	--	--	0.590
Power Displacement (cu.ft./mile)		236.3	236.3	205.9
Displacement Factor (cu.ft./ton mile)		129.2	128.5	112.7

## GLOSSARY

Performance Weight	Curb Weight plus 300 Lb. (weight of two 150 lb. passengers)
Power Displacement	$\frac{\text{Crankshaft Revs/Mi} \times \text{Piston Displacement}}{2 \times 1728}$
Displacement Factor	$\frac{\text{Power Displacement}}{\text{Performance Wt (tons)}}$

# PRINCIPAL COMPONENTS

## CYLINDER BLOCK

Material	Cast alloy iron
Bore	
5.0 Liter V-8	3.7355-3.7385
5.7 Liter V-8	3.9995-4.0025
Bore Spacing (C to C)	4.40
Bearing Caps (Number, material & attachment)	
5.0 Liter V-8	5, gray iron, 2-bolts
5.7 Liter V-8 (L48)	5, gray iron, 2-bolts
5.7 Liter V-8 (L82)	5, gray iron, 4-bolts
Water Jackets	Full length around each cylinder

## CYLINDER HEAD

Material	Light weight cast iron
Bolt Number	34
Bolt Size	.4375 dia.; 14 threads/in.

## COMBUSTION CHAMBER VOLUME

(Total chamber volume of assembled engine with piston at top center) - Cu. In.	
5.0 Liter V-8	5.013
5.7 Liter V-8 (L48)	5.94
5.7 Liter V-8 (L82)	5.47

## INLET MANIFOLD

Material	Aluminum
Type	8 port, double deck

## EXHAUST MANIFOLD

Material	Cast alloy iron
Type	Rams horn - Federal; stamped and tubular - California
Outlet Dia. (nominal)	2.50

## CRANKSHAFT

Material	
5.0 Liter V-8	Nodular cast iron
5.7 Liter V-8 (L48)	Nodular cast iron
5.7 Liter V-8 (L82)	Forged steel
End Play	.002-.007
Counterweights	6
Crank Arm Length	1.74
Torsional Damper	Sintered iron
Timing Gear	Sintered iron; sprocket & chain Pulley P. D.
5.0 Liter V-8	7.58
5.7 Liter V-8 (L48)	7.58
5.7 Liter V-8 (L82)	6.54

## 5.7 LITER V-8 ENGINES

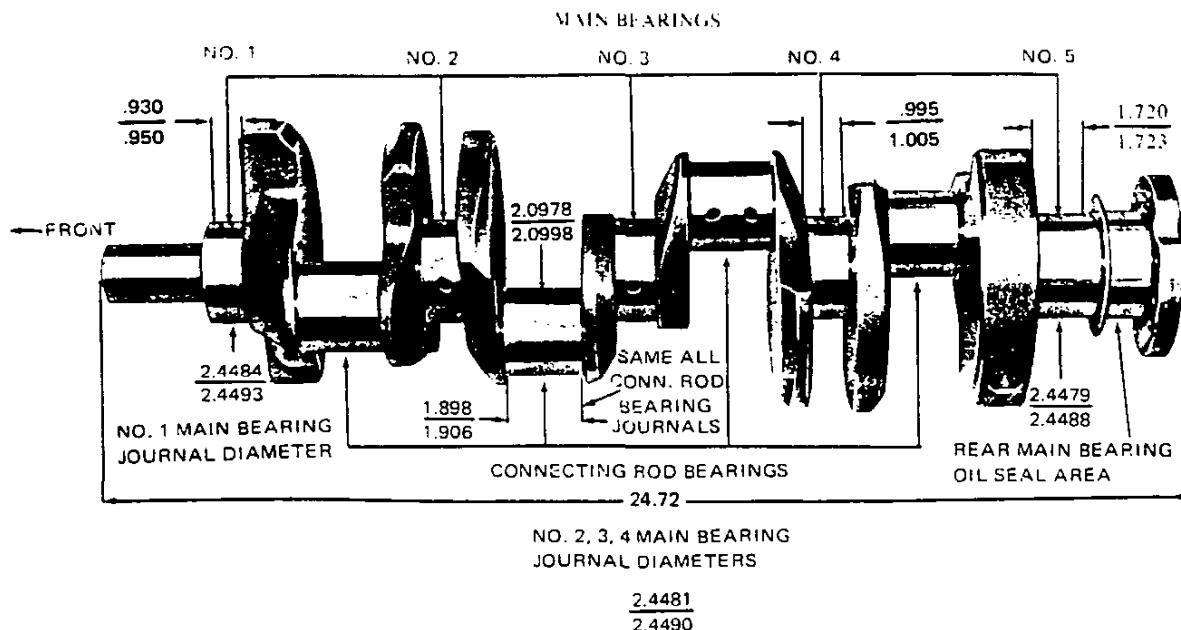

# PRINCIPAL COMPONENTS

## MAIN BEARINGS

Type . . . . . Precision removable  
 Material . . . . . No. 1 - G66 Conecc; No. 2, 3, 4 - M400;  
 No. 5 upper - M100; No. 5 lower w/M.T. - M100,  
 w/A.T. - M400.  
 Thrust Against Bearing Number . . . . . 5  
 Clearance  
 Bearing No. 1 . . . . . .0008-.0020  
 Bearing No. 2, 3, 4 . . . . . .0011-.0023  
 Bearing No. 5 . . . . . .0017-.0033

Dimensions	Theoretical Inner Dia.	Effective Length	Projected Area
Bearing No. 1-4	2.4502	.752	i .343
Bearing No. 5	2.4508	1.180	2.8919

## CAMSHAFT

Material . . . . . Cast alloy iron  
 Drive . . . . . Chain  
 Gear . . . . . Nylon teeth with aluminum hub  
 Lobe Lift  
 5.0 Liter V-8 . . . . . .2484 inlet; .2667 exhaust  
 5.7 Liter V-8 (L48) . . . . . .2600 inlet; .2733 exhaust  
 5.7 Liter V-8 (L82) . . . . . .3000 inlet; .3067 exhaust  
 Bearings . . . . . 5, steel backed babbit

## VALVE LIFT

5.0 Liter V-8 . . . . . .3570 inlet; .3900 exhaust  
 5.7 Liter V-8 (L48) . . . . . .3900 inlet; .4100 exhaust  
 5.7 Liter V-8 (L82) . . . . . .4500 inlet; .4600 exhaust

## VALVE TRAIN

Type . . . . . Individually mounted  
 overhead rocker arms, push rod actuated  
 Lifters . . . . . Hydraulic  
 Push Rods  
 Type . . . . . Steel tubing  
 Ends  
 5.0 Liter V-8 . . . . . Carbonitrided, formed  
 5.7 Liter V-8 (L48) . . . . . Carbonitrided, formed  
 5.7 Liter V-8 (L82) . . . . . Carbonitrided, C1040  
 insert in rocker arm end

## Rocker Arms

Material  
 5.0 Liter V-8 . . . . . Steel, carbonitrided  
 5.7 Liter V-8 (L48) . . . . . Steel, carbonitrided  
 5.7 Liter V-8 (L82) . . . . . Sintered iron, heat treated  
 Ratio . . . . . 1.50:1  
 Rotators . . . . . Exhaust

## VALVE SPRINGS

Diameter (I.D.) - In. . . . . .868-.884  
 Installed Length (lb. @ in.)  
 Valve Closed . . . . . 76-84 @ 1.70  
 Valve Opened  
 5.0 Liter V-8  
 Intake . . . . . 175 @ 1.25  
 Exhaust . . . . . 184 @ 1.16  
 5.7 Liter V-8 (L48)  
 Intake . . . . . 180-188 @ 1.25  
 Exhaust . . . . . 186-194 @ 1.16  
 5.7 Liter V-8 (L82)  
 Intake . . . . . 196-204 @ 1.25  
 Exhaust . . . . . 197-209 @ 1.25  
 Free Length . . . . . 2.03  
 Valve Spring Damper . . . . . Flat steel, 4 coils

# PRINCIPAL COMPONENTS

## INLET VALVES

Material	
5.0 Liter V-8	21-2N steel
5.7 Liter V-8	SAE-1541-H, forged steel
Coating	
5.0 Liter V-8	Full chrome
5.7 Liter V-8	Chrome flash stems

## EXHAUST VALVES

Material	21-2N steel
Coating	Aluminized head
Stems	Chrome flash

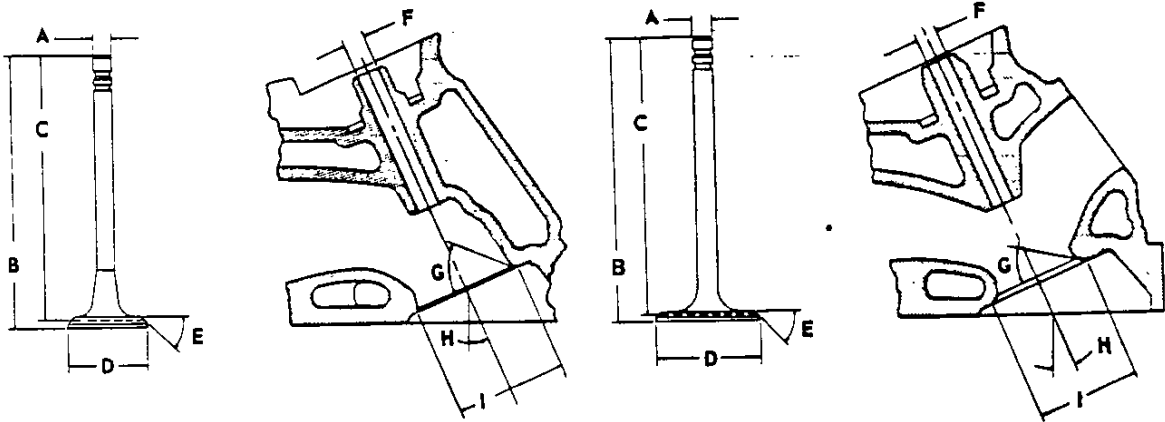

A - Stem Diameter	.3410-.3417
B - Overall Length	
5.0 Liter V-8	4.910-4.930
5.7 Liter V-8	4.870-4.889
C - Gage Length	
5.0 Liter V-8	4.781-4.791
5.7 Liter V-8	4.785-4.795
D - Overall Head Diameter	
5.0 Liter V-8	1.84
5.7 Liter V-8	1.94
E - Angle of Face (°)	45
F - Guide Diameter	.3427-.3437
G - Angle of Seat (°)	46
H - Valve Angle (°)	23
I - Valve Seat (Cutter) Diameter	
5.0 Liter V-8	1.823-1.829
5.7 Liter V-8	1.949-1.979

A - Stem Diameter	.3410-.3427
B - Overall Length	
5.0 Liter V-8	4.913-4.933
5.7 Liter V-8 (L48)	4.910-4.930
5.7 Liter V-8 (L82)	4.891-4.910
C - Gage Length	4.781-4.791
D - Overall Head Diameter	1.50
E - Angle of Face (°)	45
F - Guide Diameter	.3427-.3437
G - Angle of Seat (°)	46
H - Valve Angle (°)	23
I - Valve Seat (Cutter) Diameter	
5.0 Liter V-8	
5.7 Liter V-8	



# PRINCIPAL COMPONENTS

## PISTONS

Material	
5.0 Liter V-8	Cast aluminum
5.7 Liter V-8 (L48)	Cast aluminum
5.7 Liter V-8 (L82)	Forged aluminum
Head Type	
5.0 Liter V-8	Sump
5.7 Liter V-8 (L48)	Sump
5.7 Liter V-8 (L82)	Flat
Skirt Type	
	Closed
Top Land Clearance	
5.0 Liter V-8	.0245-.0335
5.7 Liter V-8 (L48)	.0235-.0325
5.7 Liter V-8 (L82)	.0305-.0395
Skirt Clearance	
5.0 Liter V-8	.0008-.0042
5.7 Liter V-8 (L48)	.0007-.0017
5.7 Liter V-8 (L82)	.0046-.0056
Compression Ring Groove Depth	
5.0 Liter V-8	.2003-.2073
5.7 Liter V-8	.2218-.2308
Oil Ring Groove Depth	
5.0 Liter V-8	.2103-.2193
5.7 Liter V-8	.2038-.2128
Pin Bore Offset	
5.0 Liter V-8	.055-.065
5.7 Liter V-8 (L48)	.055-.065
5.7 Liter V-8 (L82)	On center
Compression Height	
	1.56

## PISTON PINS

Material	Chromium steel
Length	2.990-3.010
Diameter	.9270-.9273
Clearance in Piston	
5.0 Liter V-8	.00025-.00035
5.7 Liter V-8 (L48)	.00025-.00035
5.7 Liter V-8 (L82)	.00045-.00055
Pin Mounting	Locked in rod by shrink fit

## VALVE TIMING (Crankshaft Degrees - Excluding Ramps)

5.0 Liter V-8	
Inlet Valve	
Opens - °BTC	28
Closes - °ABC	64
Duration	272
Exhaust Valve	
Opens - °BBC	78
Closes - °ATC	30
Duration	288
5.7 Liter V-8 (L48)	
Inlet Valve	
Opens - °BTC	28
Closes - °ABC	72
Duration	280
Exhaust Valve	
Opens - °BBC	78
Closes - °ATC	30
Duration	288
5.7 Litre V-8 (L82)	
Inlet Valve	
Opens - °BTC	52
Closes - °ABC	114
Duration	346
Exhaust Valve	
Opens - °BBC	98
Closes - °ATC	62
Duration	340

## COMPRESSION RING – UPPER

Material	Cast alloy iron
Type	Straight edge inside of ring
Face	Radius
Coating	
5.0 Liter V-8	0.01 mm (.0004 in) chrome flash
5.7 Liter V-8 (L48)	0.01 mm (.0004 in) chrome flash
5.7 Liter V-8 (L82)	Moly channel
Width	
5.0 Liter V-8	.0770-.0780
5.7 Liter V-8 (L48)	.0775-.0780
5.7 Liter V-8 (L82)	.0770-.0775
Wall Thickness	
5.0 Liter V-8	.167-.177
5.7 Liter V-8	.190-.200
Gap	.010-.020

## COMPRESSION RINGS – LOWER

Material	Cast alloy iron
Type	Reverse twist
Face	Tapered
Coating	Lubrited
Width	
5.0 Liter V-8	.0775-.0780
5.7 Liter V-8 (L48)	.0770-.0775
5.7 Liter V-8 (L82)	.0770-.0775
Wall Thickness	
5.0 Liter V-8	.167-.177
5.7 Liter V-8	.190-.200
Gap	.013-.025

## OIL CONTROL RINGS

Type	Multi-piece (two rails and one spacer)
Material	
5.0 Liter V-8	TRW T-flex design, .05 mm (.002") minimum chrome
5.7 Liter V-8	Stainless steel - 50 L48 .002" minimum chrome
L82	.006" minimum chrome
Width (assembled)	
5.0 Liter V-8	.178-.182
5.7 Liter V-8	.185-.187
Wall Thickness	
5.0 Liter V-8	.138-.144
5.7 Liter V-8	.150-.156
Gap	
5.0 Liter V-8	.010-.035
5.7 Liter V-8	.015-.055

## CONNECTING RODS

Material	1037 or 1038 steel
Length (center to center)	5.695-5.705

## CONNECTING ROD BEARINGS

Type	Precision, removable
Material	Premium aluminum
Clearance	.0013-.0035
Effective Length	.797
End Play	.006-.016

# FUEL AND EXHAUST SYSTEM

## FUEL SYSTEM

### FUEL TANK

Location . . . . . In body cavity at rear of deck area  
Capacity - gallons . . . . . 24 (approximately)  
Filler Location . . . . . Center of rear deck area

### FUEL FILTERS, DUAL

In Fuel Tank . . . . . Fine mesh plastic strainer  
In Carburetor Inlet . . . . . Paper filter element

### FUEL PUMP

Type . . . . . Mechanical, push rod type  
Drive . . . . . Camshaft eccentric  
Location . . . . . Lower right front of engine  
Pressure Range . . . . . 7.50-9.00 psi at pump outlet

### AIR CLEANER

Type . . . . . Replaceable paper element, dual snorkel

### CHOKE

Type . . . . . Electric

### CARBURETORS

Type . . . . . 4-barrel, quadrajet  
SAE Flange Size . . . . . 1.50  
Throttle Bore  
Primary . . . . . 1.38  
Secondary . . . . . 2.25  
Venturi  
Primary . . . . . 1.09  
Secondary . . . . . Air valve  
Secondary Throttle Actuation . . . . . By linkage  
approximately when primary valves are opened  
half between closed and open.

## EXHAUST SYSTEM

### MUFFLERS

Type . . . . . Dual exhaust with single converter  
Construction . . . . . Heads and body joined  
by rolled lock seam construction  
Shell . . . . . Sheet heat steel aluminum coating  
Wrap . . . . . Indented asbestos sheet  
Cover . . . . . Stainless steel outer wrap  
Heads . . . . . Sheet steel aluminum coating  
Body  
Length . . . . . 16.00  
Width (I. D.) . . . . . 9.00  
Height (I. D.) . . . . . 7.00

### EXHAUST PIPES

Front 'Y' Pipes  
Type . . . . . Dual  
Material . . . . . Stainless steel tubing  
Diameter . . . . . 2.50  
Exhaust Pipe to Converter  
Type . . . . . Dual with heat shield on  
left hand pipe  
Material . . . . . Stainless steel tubing  
Diameter . . . . . 2.50  
Converter to Muffler  
Type . . . . . Dual  
Material . . . . . Stainless steel tubing  
Diameter . . . . . 2.50

### TAIL PIPES

Type . . . . . Dual  
Material . . . . . Aluminum coated tubing  
Diameter . . . . . 2.00

# EMISSION CONTROL EQUIPMENT

## SYSTEM APPLICATION

SYSTEM TYPE	ENGINE ADAPTATION		
	5.0 Liter V-8 (LG4)	5.7 Liter V-8 (L48)	5.7 Liter V-8 (L82)
	305 CID	350 CID	
	Calif.	Federal	
AIR - Air Injection Reactor	X	X	X
CHA - Carburetor Hot Air	X	X	X
EFE - Early Fuel Evaporation	X	X	X
P-EGR - Exhaust Pressure Modulated EGR	X	X	X
COA - Carburetor Outside Air	X	X	X
UFC - Underfloor Converter	-	X	X
C-4 - Computer Controlled Catalytic Converter	X	-	-
FEC - Fuel Evaporation Control	X	X	X
PCV - Positive Crankcase Ventilation	X	X	X

## BASIC FUNCTIONS OF SYSTEMS

### AIR INJECTION REACTOR

Compresses, regulates and distributes quantities of air to the exhaust to more completely burn carbon monoxide and hydrocarbon emissions.

### CARBURETOR HOT AIR SYSTEM

A thermostatically controlled air induction system designed to aid carburetion. Consists of a heat stove to supply preheated air and a vacuum powered damper to mix air normally drawn in through the snorkel with the hot air. Produces a more uniform carburetor air temperature which permits proper emission control with improved engine operation.

### EARLY FUEL EVAPORATION

A thermostatically controlled system designed to supply hot exhaust gasses to heat carburetor base and inlet manifold during early stages of cold engine operation. Improves cold engine driveability during warm-up.

### EXHAUST PRESSURE MODULATED EGR

Meters exhaust gas into induction system for recirculation throughout the combustion cycle to reduce oxides of nitrogen emissions. Exhaust pressure modulation in addition to vacuum modulation to increase control perimeters.

### CARBURETOR OUTSIDE AIR

Duct work connecting air cleaner snorkel to air source outside of engine compartment. Provides cooler outside air to CHA system for improved performance after engine warm-up.

### UNDERFLOOR CATALYTIC CONVERTER

A device placed in the exhaust system containing the catalytic bed through which exhaust gasses are passed. The catalyst may be configured to cause both a reduction and oxydation reaction, or an oxydation reaction only.

### COMPUTER CONTROLLED CATALYTIC CONVERTER SYSTEM

A system designed to monitor engine functions and through an on-board computer, combine precise electronic carburetor control of fuel-air ratio near the stoichiometric with an oxidation-reduction catalytic converter to control emissions. This system achieves low levels of hydrocarbons and carbon monoxide emissions while significantly lowering oxides of nitrogen.

### FUEL EVAPORATION CONTROL SYSTEM

Controls emission of gasoline vapors to the atmosphere by means of an integral separator chamber within the fuel tank that separates vapor from liquid fuel - a filler cap that doesn't permit venting into the atmosphere - a canister for storage of vapors - lines, hoses and valves to control and transport vapors from fuel tank and carburetor float bowl to storage, and finally, to the carburetor for utilization in running the engine.

### POSITIVE CRANKCASE VENTILATION

Withdraws oil and gas vapors from the various cavities throughout the engine for burning in the combustion cycle.

# LUBRICATION SYSTEM

## GENERAL

Type . . . . . Controlled full pressure  
Main Bearings . . . . . Pressure  
Connecting Rods . . . . . Pressure  
Piston Pins . . . . . Splash  
Cylinder Walls . . . . . Pressure, jet cross sprayed  
Camshaft Bearings . . . . . Pressure  
Valve Lifters . . . . . Pressure  
Rocker Arms . . . . . Pressure  
Timing Gears . . . . . Centrifugally oiled from front  
camshaft bearing  
Oil Pressure Sending Unit . . . . . Electric  
Oil Filler  
Cap . . . . . Positive seal  
Location . . . . . Top rear of left rocker cover

## OIL PUMP

Type . . . . . Gear  
Normal Oil Pressure . . . . . 45 PSI @ 2000 RPM  
Intake Type . . . . . Fixed  
Capacity (GPM @ Eng. RPM) . . . . . 4.3 @ 2000  
Regulator Valve . . . . . Opens between 40-45 lbs

## OIL DIP STICK

Location . . . . . Right side, rear of engine block

## OIL PAN CAPACITY (Quarts)

Refill . . . . . 4.0  
Refill with Filter Change . . . . . 4 1/2

## OIL FILTER

Type . . . . . Full flow, throwaway canister  
Location . . . . . Left rear underside of engine  
Capacity . . . . . 0.625 qt.  
By-pass Valve . . . . . Opens between 9 to 11 PSI

## LUBRICANT GRADES AND TEMPERATURES

20°F and Above . . . . . 10W-30, 10W-40, 20W-20,  
20W-40, 20W-50  
0°F to 60°F . . . . . 10W, 5W-30, 10W-30, 10W-40  
Below 20°F . . . . . 5W-20, 5W30

## OIL PAN

Type of Drain Plug . . . . . Hex head  
Location . . . . . Lower rear face of oil pan sump  
Size Hex Head . . . . . .860-.875  
Thread . . . . . 1/2-20 UNF 2A  
Length . . . . . 0.81  
Diameter . . . . . .410-.430

# COOLING SYSTEM

## GENERAL

Type	Pressure, vented thru coolant recovery system
Capacity - Quarts	
5.0 Liter V-8	21.5
5.7 Liter V-8	21.6

## RADIATOR

Type	Cross flow
Core Constant and Thickness	
Distance between Fins	
5.0 Liter V-8	.12
5.7 Liter V-8	.18
Distance between Tubes	.55
Core Thickness	
5.0 Liter V-8	1.58
5.7 Liter V-8	2.68
Frontal Area (sq. in.)	
5.0 Liter V-8	444
5.7 Liter V-8	446
Overflow	Separate coolant bottle

## RADIATOR HOSE

Outlet, Lower (Radiator to Water Pump) - I.D.	
5.0 Liter V-8	1.50
5.7 Liter V-8	1.75
Inlet, Upper (Thermostat Hsg. to Radiator) - I.D.	1.50

## RADIATOR CAP RELIEF VALVE

Opens at (approximately)	15 psi
--------------------------	--------

## FAN

Number of Blades	5
Diameter	17.5
Fan Pulley P. D.	
5.0 Liter V-8	6.06
5.7 Liter V-8 (L48)	6.06
5.7 Liter V-8 (L82)	5.77
Fan Cutout	Thermomodulated viscous type clutch
Electric Fan, Auxiliary	
Application	RPO L82
Number of Blades	7
Diameter	15.0

## THERMOSTAT

Type	Pellet
Begins to Open at (°F)	192-198
Fully Opened at (°F)	227

## BELT - CRANKSHAFT, FAN AND ALTERNATOR

Number Used	Two
Angle of 'V' (°)	34-38
Pitch Line	
Fan, Alternator and Water Pump	52.00
Air Injection Reactor	32.50
Width	.380

## WATER PUMP

Type	Centrifugal
Capacity (GPM @ engine RPM)	22.7 @ 2000
Bearing	Permanently lubricated double row ball
Drive	Fan belt
Ratio (pump to engine RPM)	
5.0 Liter V-8	1.25:1
5.7 Liter V-8 (L48)	1.25:1
5.7 Liter V-8 (L82)	1.13:1

## DRAIN LOCATIONS

Engine Block	
Type	Plug
Location	Right and left center
Radiator	
Type	Plug
Location	Bottom right side



# TRANSMISSIONS AND CLUTCHES

## CLUTCH

Engine	Type	5.7 Liter V-8	
	Availability	RPO L48	
Type		Single dry disc, semi-centrifugal	
Clutch cover & pressure plate	Eff. plate load, lbs.	2100-2300	
	Press. plate material	Nodular iron	
	Clutch spring type	Circular plate diaphragm, bent finger design	
	Clutch spring material	Heat treated spring steel	
Driven plate	Type	Single disc with two friction surfaces	
	Cushions	Flat spring steel between friction rings	
	Dampers	10 coil springs (5 sets of two) each plate	
	Friction rings	OD	10.34
		ID	6.50
Total sq. in.		101.6	
Material		Woven type asbestos	
Flywheel	Flywheel	Material	Nodular iron
		Material	Heat treated HR steel
	Ring gear	No. of teeth	168
		PD	14.00
		Attachment	Shrink fit
Bearings	Release	Type	Single row ball
		Lubrication	None, prepacked
	Pilot	Type	Bronze bushing
		Lubrication	None, sintered and oil impregnated
Controls	Clutch fork	Drop forged steel, pivot mounted on ball	
	Pedal mounting	Pendant, from brace on dash	
	Lubrication	Crossover shaft	
Clutch housing material		Aluminum alloy	

## 4-SPEED TRANSMISSION

Engine Application - 5.7 Liter V-8		RPO L48	
Transmission Type - 4-Speed		RPO M18	
Case Material		Aluminum	
Gear Shift	Type	Remote	
	Control	Lever	
	Location	Floor, mounted in console	
Gears	Type	Helical	
	Material	Forged steel, hardened	
	Synchronization	All forward gears	
	Constant mesh gear	All forward gears	
	Sliding gears	Reverse	
	Ratios	First	2.88
		Second	1.91
		Third	1.33
Fourth		1.00	
Reverse		2.78	
Lubricant	Type	GL-5 Gear Lubricant (80W or 80W-90)	
	Capacity (pts)	3.4	
Extension	Material	Aluminum	
	Oil Seal	Steel encased seal of spring loaded Silicone	



# TRANSMISSIONS

## THREE-SPEED AUTOMATIC

Engine		5.0 Liter V-8	5.7 Liter V-8	
General Data	Type	Automatic hydraulic torque converter with compound planetary gear system - three forward speeds and reverse.		
	Selector lever	Location	Center floor console	
		Operation	Actuates controls by a hydraulic system from pressurized gear type pump	
		Quadrant pattern	P-R-N-D-L2-L1	
	Parking Lock	Type	Locking pawl	
		Operation	Applied by selector lever through manual linkage	
	Method of cooling	Water		
	Flywheel assembly	Steel stamping with welded on ring gear		
Oil pressure pump	Supplies hydraulic pressure from an engine driven gear type pump			
Hydraulic System	Type	Steel spool valve		
	Valves	Manual	Establishes range of transmission operation	
		Pressure regulator	Provides main line pressure	
		Shift (1-2)	Controls oil pressure for transmission shift from 1-2 or 2-1	
		Shift (2-3)	Controls oil pressure for transmission shift from 2-3 or 3-2	
	Modulator	Regulates line pressure with modulator oil pressure which varies with torque to transmission		
	Accumulator	Provides greater flexibility in attaining desired shift quality for various engine requirements		
	Pressure @ Idle (a)	Drive	60	
		L2	87	
		L1	87	
Reverse		91		
Converter Assembly	Pump (Drive member)	Multivane type, sheet metal blade spot welded to steel pump housing that is an integral part of the converter housing		
	Turbine (Driven member)	Steel axial flow blades assembled between inner & outer steel shells		
	Stator assembly	Aluminum multivane type blades mounted on a one way (overrunning) roller clutch		
	Stall ratio	2.00		
	Stall speed (RPM)	2110		
	Diameter (nominal)	12.2	11.75	
Planetary Gear Set	Reaction carrier assembly	4 steel pinion gears		
	Output carrier assembly	4 steel pinion gears		
	Intermediate band	Circular steel with organic lining		
	Range	D (Drive)	2.52:1 - 1.52:1 - 1.00:1	
		L2 (Low two)	2.52:1 - 1.52:1	
		L1 (Low one)	2.52:1	
R (Reverse)		1.93:1		
Servo Unit	Piston with release spring and inner cushion spring			
Case	Material	Aluminum		
Clutches	Type	Four, multiple disk		
	Material	Drive plates	Steel with bonded organic facings	
		Driven plates	Flat steel	
	Forward clutch	5 each drive & driven plates		
	Direct clutch	4 each drive & driven plates		
	Intermediate clutch	3 each drive & driven plates		
	Low & Reverse clutch	5 each drive & driven plates		
	Release spring	Radial row steel coil		
Torque Multiplication	Drive (maximum)	5.04:1 to 1.00		
	Low 2	5.04:1 to 1.52		
	Low 1	5.04:1 to 2.52		
	Reverse	3.86:1 to 1.93		
Governor	Type	Cross-axis centrifugal		
	Operation	Regulates a pressure proportional to car speed which acts upon the (1-2) (2-3) shift and modulator valves		
Lubricant	Type	Dexron II		
	Capacity (pints)	Dry	20	
		Refill	5	

(a) Condition 600 RPM input  
Converter clutch used with 5.7 liter V-8 engine.

# DIMENSIONS AND WEIGHTS

INTERIOR DIMENSIONS .....	2
EXTERIOR DIMENSIONS .....	3,4
VEHICLE WEIGHTS .....	5
OPTIONAL EQUIPMENT WEIGHTS .....	5

# INTERIOR DIMENSIONS

## FRONT COMPARTMENT

CODE	DESCRIPTION	1YZ87 COUPE
H30	SgRP to heel point	162 ( 6.4)
H37	Headlining to roof height	16.2 ( .64)
H58	H point rise	25.4 ( 1.0)
H61	Effective headroom	919 (36.2)
H67	Depressed floor covering thickness	20.1 ( .79)
H70	SgRP to body base grid	178 ( 7.0)
H75	Effective "T" point head room	935 (36.8)
L17	H point travel - design	137 ( 5.4)
L31	SgRP front, "X" coordinate	1135 (44.7)
L34	Maximum effective leg room - accelerator	1069 (42.1)
L40	Back angle (degrees)	33°
L42	Hip angle (degrees)	99°
L44	Knee angle (degrees)	126.0°
L46	Foot angle (degrees)	88.0°
L53	H point to accelerator floor point	886 (34.9)

## SEAT AND ENTRANCE

H3	Seat chair height	221 ( 8.7)
H11	Entrance height	737 (29.0)
H26	Interior body height, M/M @ car centerline	820 (32.3)
H27	Interior body, M/M @ C/LO	975 (38.4)
H32	Seat cushion deflection	58.4 ( 2.3)
H50	Upper body opening to ground	1120 (44.5)
W3	Shoulder room	1206 (47.5)
W5	Hip room	1267 (49.9)
W16	Seat width (each seat)	508 (20.0)
L14	Seat back thickness	91.4 ( 3.6)
L18	Entrance foot clearance	335 (13.2)

## VISION AND CONTROL

H6	H point to W/S bottom DLO	523 (20.6)
H13	Steering wheel thigh clearance	48.3 ( 1.9)
H18	Steering column angle (degrees) horizontal	15°
H25	Belt height	439 (17.3)
H49	H point to top of steering wheel	40.6 ( 1.6)
W7	Steering wheel center to car centerline	325 (12.8)
W9	Steering wheel maximum O.D.	14.25 x 14.75 oval
W122	Tumble-home (degrees)	188 ( 7.4)
L7	Steering wheel torso clearance	401 (15.8)
L13	Brake pedal knee clearance	592 (23.3)
L52	Brake pedal to accelerator	86.4 ( 3.4)

## LUGGAGE COMPARTMENT

V1	Luggage Capacity - Usable liters (Cu.Ft.)	238 (8.4)
----	---	-----------

\* Primary Dimensions are millimeters unless otherwise shown.

## EXTERIOR DIMENSIONS

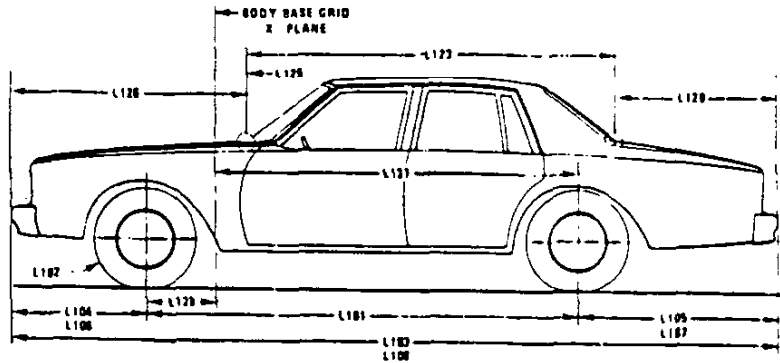

### LENGTHS

CODE	DESCRIPTION	1Y287 COUPE
L101	Wheelbase	2489 (98.0)
L102	Tire size (standard)	P225/70R15
L103	Overall length	4707 (185.3)
L104	Overhang - front	1077 ( 42.4)
L105	Overhang - rear	1141 ( 44.9)
-	Overall length - less bumpers	4412 (173.7)
L123	Body upper structure length at car center line	2090 ( 82.3)
L125	Body base grid plane to windshield cowling point	409 ( 16.1)
L126	Front end length at centerline	2144 ( 84.4)
L127	Rear wheel centerline to body base grid line	1829 ( 72.0)
L128	Front wheel centerline to body base grid line	- 660 (- 26.0)
L129	Rear end length at centerline	1214 ( 47.8)
L30	Front of dash to body base grid	- 43 (- 1.7)

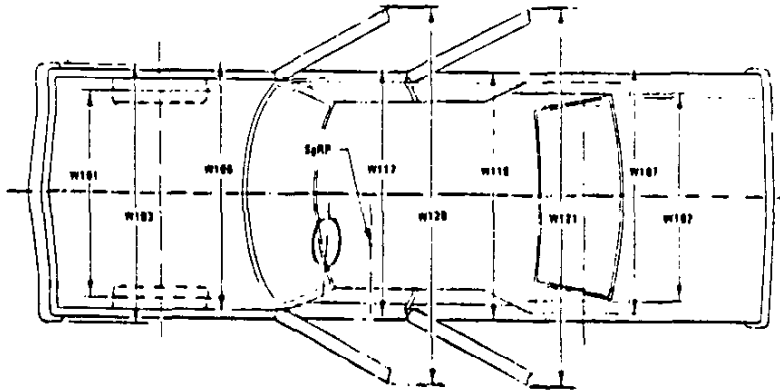

### WIDTHS

W101	Tread - front	1491 ( 58.7)
W102	Tread - rear	1511 ( 59.5)
W103	Maximum overall width of car	1753 ( 69.0)
W106	Front fender overall width	1753 ( 69.0)
W107	Rear fender overall width	1747 ( 68.8)
W116	Maximum overall width of body	1753 ( 69.0)
W120	Overall car width, front doors open	3467 (136.5)

\* Primary Dimensions are millimeters unless otherwise shown.

# EXTERIOR DIMENSIONS

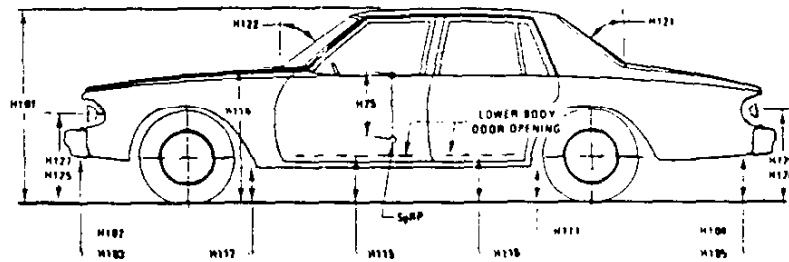

## HEIGHTS

CODE	DESCRIPTION	1YZ87 COUPE
H101	Overall height (design)	1222 (48.1)
H102	Front bumper to ground	239 ( 9.4)
H104	Rear bumper to ground	289 (11.4)
H111	Rocker panel to ground - rear	195 ( 7.7)
H112	Rocker panel to ground - front	206 ( 8.1)
H114	Hood at rear to ground	899 (35.4)
H115	Step height - front (design)	338 (13.3)
H116	Step height - rear (design)	--
H125	Headlamp to ground	663 (26.1)
H126	Tail lamp to ground	635 (25.0)
H136	Body O line to ground - front	206 ( 8.1)
H137	Body O line to ground - rear	190 ( 7.5)

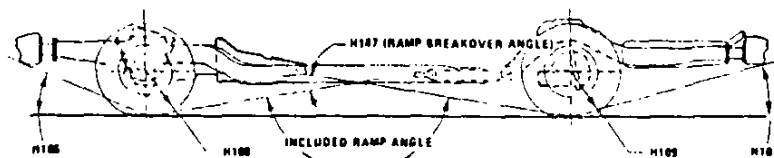
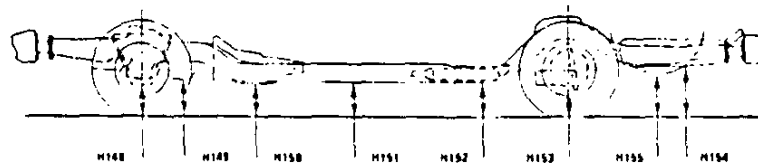

## CLEARANCES

H106	Angle of approach (degrees)	13.91°
H107	Angle of departure (degrees)	16.55°
H147	Ramp breakover angle (degrees)	12.49°
H148	Front suspension to ground	165 (6.5)
H149	Oil pan to ground	137 (5.4)
H150	Flywheel housing to ground	137 (5.4)
H151	Frame to ground	135 (5.3)
H152	Exhaust system to ground	203 (8.0)
H153	Rear axle to ground	145 (5.7)
H154	Fuel tank to ground	411 (16.2)
H155	Tire well to ground	117 (4.6)
H156	Minimum ground clearance	104 (4.1) (a)

(a) Catalytic converter.

\* Primary Dimensions are millimeters unless otherwise shown.

# VEHICLE WEIGHTS

## CORVETTE

MODEL DESIGNATION	BASE ENGINE	VEHICLE TYPE Description	SHIPPING WEIGHT			CURB WEIGHT		
			Front	Rear	Total	Front	Rear	Total
1YZ87	350 Cu.In. V8 (L48)	2-Door Sport Coupe	733.8 (1618)	720.3 (1588)	1454.1 (3206)	720.0 (1587)	792.3 (1747)	1512.3 (3334)

SHIPPING WEIGHT: Weight of basic vehicle with regular equipment, including grease, oil, engine coolant to capacity and (3) gallons of gasoline.

CURB WEIGHT: Shipping weight plus gasoline to capacity.

For total shipping, and curb weights of vehicles equipped with the following options, add to, or deduct from, the base vehicle weight (pounds).

## OPTIONAL EQUIPMENT

RPO	OPTION	WITH	WEIGHT
AU3	Power Door Locks		2.3 (5 lb.)
CC1	Glass Roof Panels Removable		6.3 (14 lb.)
C49	Defogger, Electro-Clear Rear Window		0.4 (1 lb.)
FE7	Suspension-Gymkhana	All Engines	2.3 (5 lb.)
F51	Shock Absorbers-Heavy Duty, Front & Rear		0.4 (1 lb.)
K30	Speed & Cruise Control	With MX1	2.3 (5 lb.)
N90	Cast Aluminum Wheels		-17.7 (-39 lb.)
UA1	Heavy Duty Battery		2.3 (5 lb.)
UM2	Radio Stereophonic AM/FM	With 8-Track Tape Player	1.4 (3 lb.)
UN3	Radio Stereophonic AM/FM	With Cassette Tape Player	0.4 (1 lb.)
UP6	Radio AM/FM Stereo CB	With Power Antenna	0.4 (1 lb.)
U58	Radio AM/FM Stereo	Fixed Height Rear Antenna and Two Front Speakers	4.8 (10.5 lb.)
U75	Antenna, Power	NA with UP6 Which Requires U83	0.9 (2 lb.)
U81	Dual Auxiliary Rear Speakers	NA with U69, UL5	1.4 (3 lb.)
U83	Power Antenna (Tri Band)	Used only with UP6	0.9 (2 lb.)
V54	Carrier-Roof Panel		7.2 (16 lb.)
LG4	5.0 Liter 305 CID V8 Engine	3-Speed Automatic Trans.	15.9 (35 lb.)
Base	5.7 Liter 350 CID V8 Engine	3-Speed Automatic Trans.	17.2 (38 lb.)
L82	5.7 Liter 350 CID V8 Engine	3-Speed Automatic Trans.	25.4 (56 lb.)

\*Primary mass weights are in kilograms (pounds).



-

-

(

)

(

)



# BODY

EXTERIOR PAINT PROCESS .....	2
EXTERIOR-INTERIOR COLORS .....	3
BODY CONSTRUCTION AND GLASS AREA .....	4



# EXTERIOR PAINT PROCESS

## EXTERIOR PAINT PROCESSING PROCEDURES

### PUTTY RUB AND SPRAY BODY PRIMER

#### Operation No.

1. Dry sand all plastic surfaces\* of body, exterior and interior to be finish painted except interior of top compartment, engine compartment and underside of front and rear fenders.
2. Vacuum all body surfaces, exterior and interior.
3. Solvent clean all surfaces with thinner applied with clean cloth.
4. Wipe on red rubbing putty on all exterior surfaces\* with substantial pressure to work putty into pits of the fiberglass.
5. Vacuum all surfaces to remove excess putty.
6. Spray primer-surfacer on all exterior surfaces, underside of front and rear fenders, engine compartment and top compartment.
7. Bake 30 minutes at 180°F.
8. Putty glaze where necessary with gray putty.
9. Water sand all exterior and interior surfaces except interior of top compartment and engine compartment.
10. Blow-off body surfaces to remove excessive moisture.
11. Putty glaze where necessary with gray putty.

\* Except panels with new "Molded Coating."

### ACRYLIC LACQUER PAINTING

#### Operation No.

1. Spray all exterior and interior surfaces with sealer.
2. Air dry 1 minute.
3. Spray Acrylic Lacquer over the exterior surfaces of the body, inside edges of the hood, inner compartment lid engine compartment drain gutters, lock and hinge pillar facings, doors and headlamp openings.
4. Flash 3 minutes minimum.
5. Bake 30 minutes at 180°F.
6. Cool body to room temperature and repair cracks or defects with resin mixture patch.
7. Wet sand body where necessary and repair defects using water for lubricant and gray putty for filing.
8. Vacuum body.
9. Spray dark gray repair primer-surfaces on body top coat areas sanded through to the primer or bare plastic.
10. Repeat operation No. 3.
11. Flash 3 minutes minimum.
12. Repeat operation No. 3.
13. Flash 3 minutes minimum.
14. Bake 30 minutes at 180°F.
15. Cool body to room temperature.
16. Mask off and spray areas outlined in Corvette Paint Instruction Drawing No. 334789.
17. Bake 30 minutes at 180°F.
18. Cool body to room temperature.
19. Using an extension gun, insert to maximum length through door access holes, spray right and left sides of door inners with aluminum preservative coating
20. Machine sand with paper using mineral spirits liberally applied as the lubricant.
21. Machine polish body to a high lustr.

# EXTERIOR-INTERIOR COLORS

1980 CORVETTE EXTERIOR COLOR CHART

DESCRIPTION	GM CODE	FISHER WA-	APPROVED MASTER SOURCE CODE
WHITE C/O	10	3465	926-97686
SILVER MET. C/O	13	4963	927-AH789
BLACK C/O	19	848	926-AJ265
DK. GREEN MET. C/O	58	8175	927-AJ525
FROST BEIGE C/O	59	7084	926-AJ222
DK. BLUE MET.	28	7193	927-E-59811
DK. CLARET MET.	76	7112	927-AJ619
DK. BROWN MET. C/O	47	4518	927-AF917
RED	83	7195	926-E-59008
YELLOW	52	7196	926-E-30710

1980 CORVETTE EXTERIOR INTERIOR COMBINATIONS

EXTERIOR COLOR	CODE	INTERIOR TRIM					
		BLACK 193L	OYSTER 12C/122L	RED 722L	DK. BLUE 29C/292L	CLARET 79C/792L	DOESKIN 59C/592L
1. BLACK c/o	19	X	X	X			X
2. WHITE c/o	10	X	X	X	X	X	X
3. SILVER c/o	13	X		X	X	X	
4. DK. GREEN MET. c/o	58		X				X
5. RED	83	X	X	X			X
6. YELLOW	52	X	X				
7. DK. BLUE MET.	28		X		X		X
8. FROST BEIGE c/o	59	X			X	X	X
9. DK. CLARET	76		X			X	X
10. DK. BROWN MET. c/o	47						X

L - Leather seating surfaces  
 C - Cloth seating surfaces

# BODY CONSTRUCTION AND GLASS AREA

## GENERAL

Construction . . . . . Uniconstruction: fiber glass reinforced plastic body backboned by a steel cage outlining the passenger compartment. Principal members – steel front and plastic rear – underbody, front and rear end assemblies, dash panel and hinge pillars are bonded, riveted, or bolted together and to each other. Hood is plastic with bonded plastic reinforcement. Two removable roof panels.

## DOORS AND LOCKS

Construction . . . . . Plastic, double paneled, reinforced with steel at hinge and lock locations. Front hinged.  
 Door handles . . . . . Press-flap handles with fork-type latches. Inside door locking knob on each door, free-wheeling 2-position inside door handles.

## HOOD

Operation . . . . . Internal release lever. Front hinged with telescoping link on right side. Ratchet-type lock for hold open.

## VENTILATION

Type . . . . . Cowl top air inlets channel air to cowl side kick panel outlets controlled by bowden cable and slide type levers mounted in instrument panel center console. Water drainage at base of "saddlebag" plenum chambers.

GRILLE . . . . . Black Injection Molded Plastic.

## SEAT CONSTRUCTION

Type and construction . . . . . Bucket with integral head restraints with leather or cloth covering on seating surface polyurethane padding. Inertia type backrest lock.

## WINDSHIELD WIPERS AND WASHERS

Type . . . . . Concealed, dual, two-speed, electric Integral washers provided in wiper arms.

## HEADLIGHTS

Type . . . . . Dual round, Halogen high beam Headlamps (Inboard), with retractable Headlamp doors, retraction system vacuum operated.

## SPARE TIRE

Location . . . . . In well under fuel tank; accessible from underside of car.

## TOOLS

Type . . . . . Scissors jack, and combination jack handle and lug wrench.  
 Stowage . . . . . In well in luggage area directly behind passenger seat; carpeted door over well.

## BODY GLASS VISIBILITY AREA ⊖

	MODEL 1YZ87
Windshield	5119 ( 793.5)
Door Window	5166 ( 800.8)
Back Window	9195 (1425.3)
Total area (sq. in.)	19480 (3019.6)

Windshield – Curved laminated safety plate (tinted)  
 Doors and Rear Window – Curved tempered safety plate (tinted).

⊖ Primary dimensions cm<sup>2</sup> (secondary dimensions in.<sup>2</sup>)

# GENERAL

MODEL IDENTIFICATION .....	2
SERIAL NUMBERS AND IDENTIFICATION .....	3
EXTERIOR EQUIPMENT .....	4
INTERIOR EQUIPMENT .....	5-6-7
EXTRA COST EQUIPMENT .....	8
AIR CONDITIONING EQUIPMENT .....	9

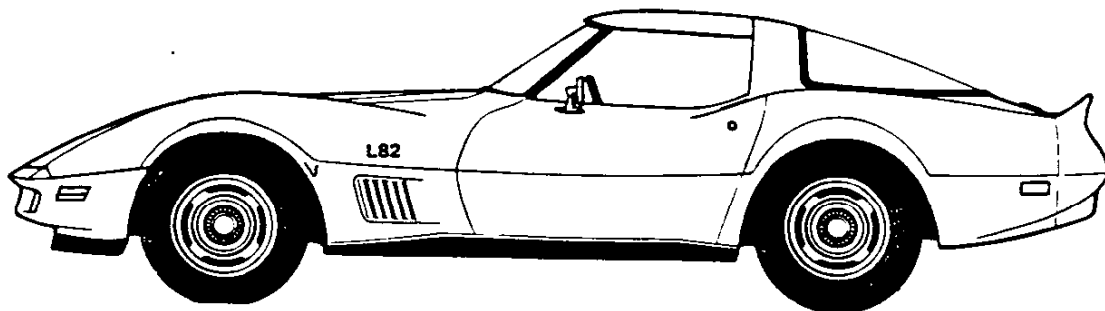

ORIGINAL COPY

# MODEL IDENTIFICATION

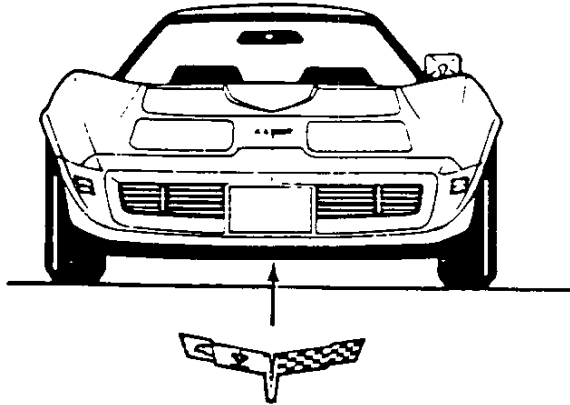

BODY	SERIES NAME	BODY STYLE	MODEL DESIGNATION	PASS OR SEATS
Y-CAR	CORVETTE	2-Dr Sport Coupe	1YZ87	2

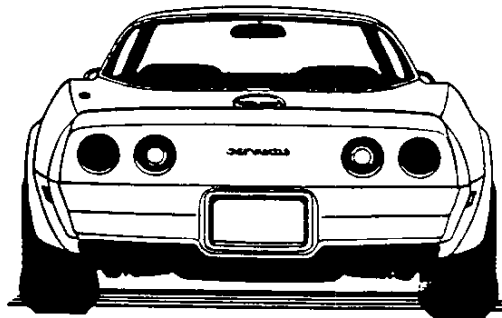

# SERIAL NUMBERS AND IDENTIFICATION

ONLY BASIC DESIGNATIONS SHOWN

## VEHICLE IDENTIFICATION NUMBER

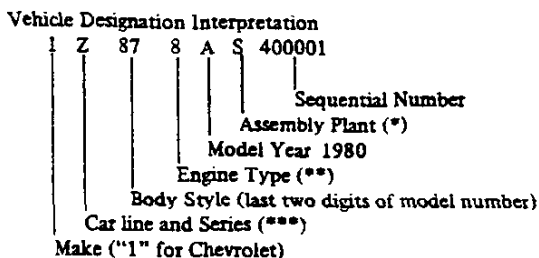

- \*S - St. Louis—GMAD
- \*\*8 - V8-350 (190 H.P.) 6-V8-350 (230 H.P.)
- H - V8-305 (180 H.P.)
- \*\*\*Z - Corvette

**EXAMPLE:** The twenty-fifth Chevrolet vehicle built at Chevrolet—St. Louis if it were a 1YZ87 model (Coupe) with a V8-350 (190 H.P.) engine would bear VIN Number 1Z878AS400025.

**Location** . . . . . Stamped on plate attached to left hand windshield pillar.

## TRANSMISSION IDENTIFICATION

**Example:** R0E01

Type Designation	Source Designation	Model Year 1980	Production <sup>o</sup> Month & Date
ZJ	R (Muncie)	0	E01D*

ZJ	4-Speed	V-8 engine	R - Muncie
7JC	3-Speed Auto.	V-8 engine	Y - Toledo

**Location:**  
 4-Speed . . . . . Stamped on the right side of the case at adapter.  
 3-Speed Automatic . . . . . Nameplate on right side transmission, above filler plug.

<sup>o</sup>Month: E denotes May; 01 denotes 1st day.  
 -Alpha Characters used in identifying the Calendar Month

- |              |           |               |              |
|--------------|-----------|---------------|--------------|
| A - January  | D - April | K - July      | R - October  |
| B - February | E - May   | M - August    | S - November |
| C - March    | H - June  | P - September | T - December |

\*-The letter "D" or "N" following the date numerals indicates day or night shift, on automatic only.

## ENGINE IDENTIFICATION

**Example:** F1210ZAM

Source Designation	Production* Month & Date	Type Designation
F (Flint)	1210	ZAM

5.7 L, 350 Cubic Inch V-8 Base Engine (RPO L48)

- ZAM - Regular engine, 4-speed, 4-bbl. carb.
- ZAK - Regular engine, 3-speed automatic, 4-bbl. carb.

5.7 L, 350 Cubic Inch V8 Engine (RPO L82)

- ZBC - Optional engine, 3-speed auto., 4-bbl. carb.

5.0 L, 305 Cubic Inch V-8 Engine California (RPO LG4)

- ZCA - Base Engine Calif., 3-Speed Automatic, 4-bbl. carb.

**Location:**  
 8-Cylinder engine . . . . . Stamped on top front of RH bank of cylinder and case, as close as possible to lower end of pad.

\*-Month: December, 12; 10th day of December, 10.

## REAR AXLE IDENTIFICATION

OF - 3.07 Axle

**Location, Identification Number**  
 Bottom edge of differential carrier flange.

See Power Train Section for additional information.

# EXTERIOR EQUIPMENT

## STANDARD EXTERIOR EQUIPMENT

### FRONT

Radiator Grille – Black Injection Molded Plastic.  
Parking Lamps – Amber Lens with Black Grille Bars.  
Retractable Headlamps, Painted Bezels  
Crossed Flags Front Identification.  
Windshield Reveal Moldings, Painted Black  
Concealed Windshield Wipers with Integral Washers in Wiper Arms  
Body Color Front Bumper Cover  
Front Plate with "Corvette" on Black Background Supplied (BY8) in States  
with No Front License Plate

### SIDE

Black Rocker Panel Molding with Bright Upper Rib.  
Front Fender Marker and Cornering Lamps  
Rear Quarter Marker Lamp  
Front Fender Air Slot, Molded in With Louver Unit.  
Outside Rear View Mirrors, LH and RH. Sport Type.  
Wheel Trim Ring and Hub Cap, Bright  
Roof Drip Molding – Painted Black  
Press-Flap Door Opening Handles – Bright  
Key Locks – Bright (LH Controls Theft Alarm)  
Door Belt Bead Molding – Bright  
"L82" Fender Emblem (RPO L82 Only)

### REAR

Rear Bumper Cover "Corvette" Nameplate.  
Single Outboard Tail Lamps.  
Single Inboard Back-Up Lamps (Includes Red Reflex).  
Rear Bumper Cover License Plate Compartment. Body Color  
Urethane Rear Bumper. Integral Spoiler.  
Crossed Flags Identification on Fuel Filler Door.  
Rear Window Reveal Molding – Painted Black

**STANDARD INTERIOR EQUIPMENT****ROOF AND PILLARS**

Molded Headlining, Padded with Sun Visor Pockets  
Windshield Garnish Moldings, Plastic, Interior Color-Keyed  
Sunshades, Padded with Brushed Hardware and Driver's Sunshade, is now the Sliding Type with Adjustment up to 3.6 Inches, and Non-Sliding Shade is Continued on the Passenger Side.  
10" Rear View Mirror, Padded, Black Back with Black Finish Support, Windshield Mounted  
Roof Center Strut, Padded, with Bright Hardware  
Top Header Release Latches, Bright  
Fixed Rear Window, Painted Frame  
Door Operated Center Dome Courtesy Light  
Coat Hook, RH Side

**SEATS AND FLOOR COVERING**

Bucket Seats – with Integral Head Restraints  
Passenger and Stowage Compartment Floor Carpet with Sound Blanket, (Interior Color-Keyed)  
Seat Adjuster Lever Knobs – Interior Color-Keyed  
Color-Keyed 3-Point Seat Belts, Non Detachable Shoulder Belts, Locking Retractors  
Floor Stowage Compartment – Single Door, Carpet Covered with Lock.  
Body Sill Plates – Bright  
Roof Panel Stowage Vinyl Bag and Tie-Down Straps, Color-Keyed

**DOOR AND QUARTER PANEL**

Door Padded Armrest with Assist Grip – Grained Vinyl with Stitching  
Door Remote Control Handle – Chrome and Painted  
Door Trim Panel, Carpeted Scuff Area with Map Pocket  
Door Locking Knob (Integral with Armrest) – Bright  
Electric Windows Base  
Kick Pad Carpeted – Interior Color-Keyed



# INTERIOR EQUIPMENT

## INSTRUMENT PANEL AND CONSOLE

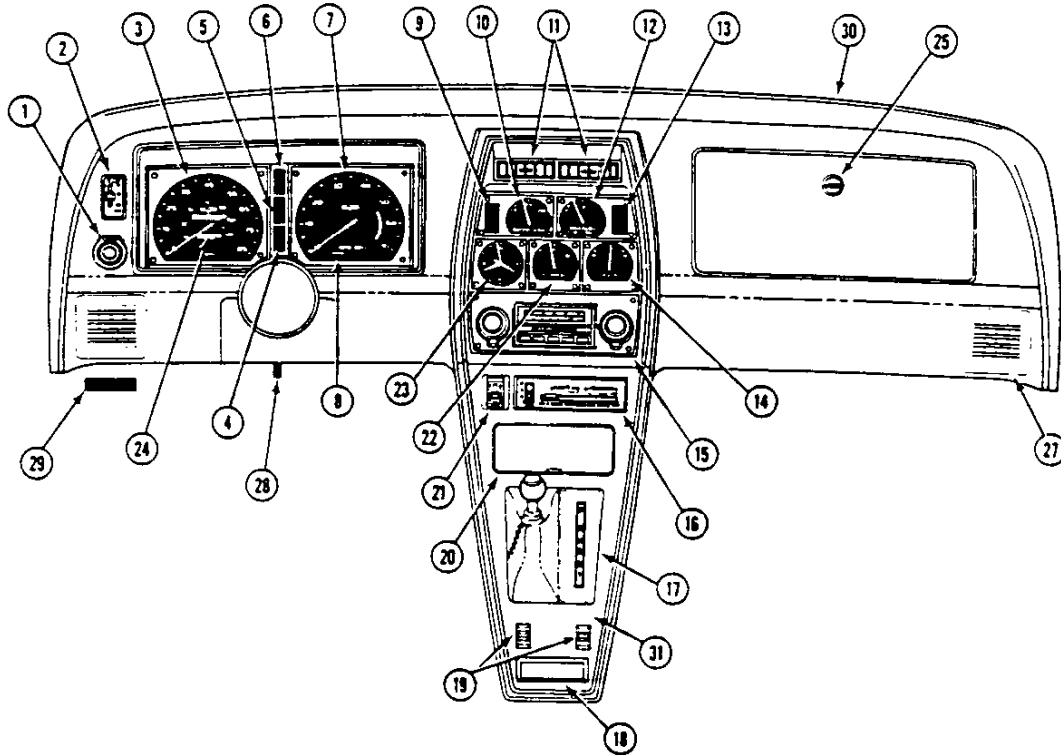

CLUSTER DETAIL  
SHOWN ON PAGE D4

4-SPEED TRANSMISSION  
SHIFT PATTERN



WHITE PAINT ON  
BLACK BACKGROUND

AUTOMATIC  
TRANSMISSION  
SELECTOR



WHITE LETTERS AND  
NUMBERS ON BLACK  
BACKGROUND, WHITE  
POINTER

## INSTRUMENT PANEL AND CONSOLE

- 1 Light and headlamp rotation switch
- 2 Windshield wiper and washer switch
- 3 5-85 mph – 10-130 km/h speedometer, odometer and trip odometer (miles) mph dominant. 55 mph accented.
- 4 Brake warning indicator – "BRAKE", red in black window
- 5 Hi-beam indicator – blue in black window
- 6 Turn signal – green in black window
- 7 7000 rpm tachometer
- 8 Electric choke indicator "CHOKE", amber in black window.
- 9 Seat belt warning indicator – "FASTEN BELTS", I.S.O. symbol, black on red lens (upper opening) "CHECK ENGINE", black on amber lens. California only (lower opening).
- 10 Water temperature gauge. Thermometer I.S.O. symbol.
- 11 Outlet, air conditioning.
- 12 Fuel gauge. "UNLEADED FUEL ONLY". Note, gas pump I.S.O. symbol.
- 13 Low fuel and generator warning indicators – "LOW FUEL" and pump tank I.S.O. symbol (upper window) black on amber lens, battery I.S.O. symbol (lower window), black on red lens. Low fuel indicator activated when fuel drops below approximately 4 gallons.
- 14 Voltmeter. Battery I.S.O. symbol.
- 15 Radio AM-FM monaural base; others RPO. Cover plate used with RPO UL5 delete radio.
- 16 Heater and air conditioning control – slide lever design.
- 17 4-Speed transmission shift pattern or automatic transmission selector.
- 18 Coin receptacle
- 19 Power window switches
- 20 Cigar lighter and ash tray
- 21 Rear window defog switch RPO C49. Small green lamp illuminated when unit is on.
- 22 Oil pressure gauge. Oil can I.S.O. symbol.
- 23 Clock with sweep second hand
- 24 Trip odometer reset knob (thru lens) – black
- 25 Glove compartment door lock – chrome. Automatic light in glove compartment.
- 27 Outlets, air conditioning (LH and RH) – black with bright treatment.
- 28 Headlamp rotation switch (independent operation) – black
- 29 Hood release – black handle with white "hood release"
- 30 Instrument panel pad – trim color
- 31 Floor center console and trim plate – low gloss black finish

## OTHER INTERIOR EQUIPMENT NOT SHOWN

Stalk on steering column controls turn signals and headlight high-low beam. Also includes cruise control switch (RPO K30) when ordered.

Parking brake lever – bright with black handgrip. On tunnel, between seats.

Color-keyed 3-spoke steering wheel with leather covered rim and crossed flags hub emblem. Black spokes.

Hazard warning switch button (black) on steering column.

Steering column ignition switch and lock – 5 position. Chrome. On steering column.

Key release lever on steering column.

# EXTRA-COST EQUIPMENT

EQUIPMENT	RPO	ACC
<b>POWER TEAMS</b>		
5.0 liter, 305 CID V8 engine (California only) . . . . .	LG4	
5.7 liter, 350 CID V8 engine - Special performances . . . . .	L82	
4-Speed manual transmission . . . . .	M18	
3-Speed automatic transmission . . . . .	MX1	
5.7 liter, 350 CID V8 engine . . . . .	L48	
3-Speed automatic transmission (California only) . . . . .	M33	
<b>OTHER OPTIONS</b>		
Power door locks . . . . .	AU3	
Glass roof panels . . . . .	CC1	
Defogger, rear window, electro-clear . . . . .	C49	
Suspension, Gymkhana - front and rear, consists of . . . . .	FE7	
Front stabilizer bar . . . . . 1.12 dia. (Base)		
Front stabilizer bar bushings . . . . . 1.06		
Front spring rate . . . . . 550 lb./in.		
Rear stabilizer bar . . . . . 0.44 dia.		
Rear stabilizer bar bushings . . . . . 0.33 dia.		
Rear spring rate . . . . . 304 lb./in. (7 leaf with spacer)		
Front and Rear shock absorbers . . . . . specific valving		
Shock absorbers - heavy duty (front & rear) . . . . .	F51	
Speed and cruise control . . . . .	K30	
Wheels, cast aluminum . . . . .	N90	
Battery heavy duty, ("Freedom" sealed battery, 4000 watts) . . . . .	UA1	
Radio equipment: Radios, pushbutton - includes rear deck antenna		
Radio, stereo AM/FM with tape player (includes fixed height rear antenna and 2-front speakers) . . . . .	UM2	
Radio AM/FM stereo with cassette tape player (includes fixed height rear antenna and 2-front speakers) . . . . .	UN3	
Radio, AM/FM stereo CB radio - includes tri-band, power antenna . . . . .	UP6	
Radio, AM/FM stereo (includes fixed height antenna and 2-front speakers) . . . . .	U58	
Radio, delete (removes receiver and speakers) . . . . .	UL5	
Antenna, power . . . . .	U75	
Dual rear auxiliary speakers . . . . .	U81	
Carrier - roof panel . . . . .	V54	
Trailer package, consists of: . . . . .	ZN1	
V08 heavy duty cooling, standard engine with MX1 transmission, and FE7 Gymkhana suspension.		
<b>FACTORY INSTALLED REGULAR PRODUCTION TIRES</b>		
P225/70R15 - hwy. - radial - white lettered steel belt . . . . .	QGR	
P255/60R15 - hwy. - radial - white lettered steel belt . . . . .	QXH	

## FOUR-SEASON (BASE EQUIPMENT)

Heater integrated; manually controlled by two sliding lever controls on instrument panel, plus a 4-speed fan switch. Left lever uses vacuum supply and electrical switches to operate mode doors and compressor. Right lever uses bowden cable to temperature door in selector duct assembly.

## BASIC COMPONENTS

Evaporator, blower, condenser, receiver - dehydrator, refrigerant (freon) tank, air intake assembly and duct assembly for both systems.

## CHASSIS

Front and Rear Springs . . . . . Heavy duty  
Rear Axle Ratio - Refer to Power Trains Section

## POWER TRAINS

Fan Blade . . . . . 7 blade  
Crankshaft Pulley . . . . . Single, two grooves  
Water Pump & Fan Pulley . . . . . Single, three grooves  
Compressor & Crankshaft Belt . . . . . One  
Generator . . . . . 63 Ampere



-

-

.

'



## ALPHABETICAL OPTION INDEX

(Not for ordering purposes)

Option Number	Description
AU3	DOOR LOCKS: Power
B3W	PRELIMINARY PRICE INFORMATION
CC1	ROOF PANELS: Removable Glass
C49	DEFOGGER, REAR WINDOW: Electric
D60	NON-RECOMMENDED COLOR COMBINATION
FE7	SUSPENSION EQUIPMENT: Suspension, Gymkhana
F51	SHOCK ABSORBERS: Heavy-Duty
K30	SPEED CONTROL: Automatic
LG4	ENGINE: 5.0 Liter 4 BBL V8
L48	ENGINE: 5.7 Liter 4 BBL V8
L82	ENGINE: 5.7 Liter 4 BBL V8
MM4	TRANSMISSION: 4-Speed Manual
MX1	TRANSMISSION: Automatic
NA5	EMISSION SYSTEM: Standard Emission Equipment
N90	WHEELS, ALUMINUM
QGQ	TIRES: P225/70 R-15 B/W (Radial)
QGR	TIRES: P225/70 R-15 W/L (Radial)
QXH	TIRES: P255/60 R-15 W/L (Radial)
UA1	BATTERY, HEAVY-DUTY
UL5	RADIO EQUIPMENT: Radio Delete
UM2	RADIO EQUIPMENT: AM/FM Stereo Radio with 8-Track Stereo Tape
UN3	RADIO EQUIPMENT: AM/FM Stereo Radio with Stereo Cassette Tape
UP6	RADIO EQUIPMENT: AM/FM Stereo/Citizens Band Radio with Power Antenna
U58	RADIO EQUIPMENT: AM/FM Stereo Radio
U75	RADIO EQUIPMENT: Power Antenna
U81	RADIO EQUIPMENT: Speakers, Dual Rear
V54	CARRIER: Roof Panel
YF5	EMISSION SYSTEM: California Emission Requirements
ZN1	CHASSIS EQUIPMENT, TRAILERING

## COLOR AND TRIM SELECTION

PLEASE NOTE: The exterior and interior combinations shown in the chart below and designated as recommended (R), represent the ideal combinations. Those that are shown as acceptable (A), are attractive, but less desirable than the recommended combinations. Orders for additional combinations may be submitted, provided the dealer orders (D60), as verification that the requested combination is definitely desired.

Interior Trim Color		Black	Beige	Blue	Claret	Red	Oyster
<b>MODEL</b>	<b>SEAT TYPE</b>						
1Y237	Leather Bucket .....	ABB2	AUU2	ADD2	ARR2	AFF2	AWW2
	Cloth Bucket .....		HUU2	HDD2	HRR2		HWW2

EXTERIOR PAINT COLOR	COLOR CODE		R	R	R	R	A	R
	L	U						
Beige, Corvette Light	59	59	R	R	R	R	A	R
Black	19	19	R	R			R	R
Blue, Corvette Dark (Met)	28	28	A	R	R		A	R
Brown, Corvette Dark (Met)	47	47	A	R				A
Claret, Dark (Met)	76	76	A	R		R		R
Green, Corvette Dark (Met)	58	58	A	R				R
Red, Corvette	83	83	R	R			R	R
Silver, Corvette	13	13	R		R	R	R	A
White, Classic	10	10	R	R	R	R	R	R
Yellow, Corvette	52	52	R					R

L Lower U Upper

## POWER TEAMS

(Refer to next page for option availability and application)

ENGINE OPTION CONDITION		AXLE RATIO
		3.07
<b>WITH NA5 STANDARD EMISSIONS</b>		
L48	MM4 or MX1	Std
L82	MX1	Std
<b>WITH YF5 CALIFORNIA EMISSIONS</b>		
LG4	MX1	Std

# CORVETTE

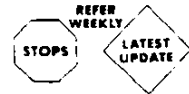

MODEL  
1YZ87 Corvette Coupe

**MUST ORDER ONE: ENGINES**

AVAILABLE WITH NA5 STANDARD EMISSION EQUIPMENT  
 \_\_\_\_\_ L48 5.7 Liter 4 BBL V8  
 \_\_\_\_\_ L82 5.7 Liter 4 BBL V8 (Reqs MX1 Trans)

AVAILABLE WITH YF5 CALIFORNIA EMISSION REQUIREMENTS  
 \_\_\_\_\_ LG4 5.0 Liter 4 BBL V8

**QUICK-SPEC**

IF TIRE AND/OR TRANSMISSION IN QUICK-SPEC IS NOT DESIRED YOU MUST "PLUS" ANOTHER TIRE AND/OR TRANSMISSION OPTION.	6	6	✓
Defogger, Rear Window Electric	C49	x	x
Radio, AM/FM Stereo	U58	x	N/I
Speakers, Dual Rear	U81	x	x
Tires, P225/70 R-15 W/L	QGR	x	x
Transmission, Automatic	MX1	x	x
Wheels, Aluminum	N90	x	x
<hr/>			
Door Locks, Power	AU3		x
Power Antenna	J75		x
Radio, AM/FM Stereo w/8 Track Stereo Tape	UM2		x
Roof Panels, Removable Glass	CC1		x
Speed Control (w/MX1 Trans onlv)	K30		x

**PLEASE REVIEW OPTION RESTRICTIONS BEFORE ORDERING**

Q-S	OPTION	
_____	UA1	BATTERY, HEAVY-DUTY: (N/A C49 Defogger)
_____	V54	CARRIER: Roof Panel
_____	ZN1	CHASSIS EQUIPMENT, TRAILERING: (Reqs L48 or LG4 Eng and MX1 Trans) (Incls FE7 Susp and HD Cooling)
615	C49	DEFOGGER, REAR WINDOW: Electric
616	AU3	DOOR LOCKS, POWER
_____		EMISSION SYSTEMS: (Must Order Only One) (See Power Teams Chart)
_____	YF5	_____California Emission Requirements
_____	NA5	_____Standard Emission Equipment
_____	B3W	PRELIMINARY PRICE INFORMATION
_____		RADIO EQUIPMENT:
615	U58	_____AM/FM Stereo Radio
616	UM2	_____AM/FM Stereo Radio w/8-Track Stereo Tape
_____	UN3	_____AM/FM Stereo Radio w/Stereo Cassette Tape
_____	UP6	_____AM/FM Stereo/Citizens Band Radio w/Power Antenna
_____	UL5	_____Radio Delete
615	U81	_____Speakers, Dual Rear (Reqs U58, UM2, UN3 or UP6 Radio)
616	U75	_____Power Antenna (N/A UL5 Radio Delete or UP6 Radio)
_____	CC1	ROOF PANELS: Removable Glass
616	K30	SPEED CONTROL: Automatic (Reqs MX1 Trans)
_____		SUSPENSION EQUIPMENT:
_____	FE7	_____Suspension, Gymkhana, Front and Rear (Incl with ZN1 Chassis Equip)
_____	F51	_____Shock Absorbers, Heavy-Duty (N/A ZN1 Chassis Equip or FE7 Susp)
_____		TIRES: (B/W: Blackwall, W/L: White Lettered)
_____		Steel Belted Radial Ply
_____	QGQ	_____P225/70 R-15 B/W (Base)
615	QGR	_____P225/70 R-15 W/L
_____	QXH	_____P255/60 R-15 W/L
_____		TRANSMISSIONS: (See Power Teams Chart)
_____	MM4	_____4-Speed Manual (Reqs L48 Eng) (N/A YF5 Calif)
615	MX1	_____Automatic
615	N90	WHEELS, ALUMINUM





# CORVETTE

## Coupe

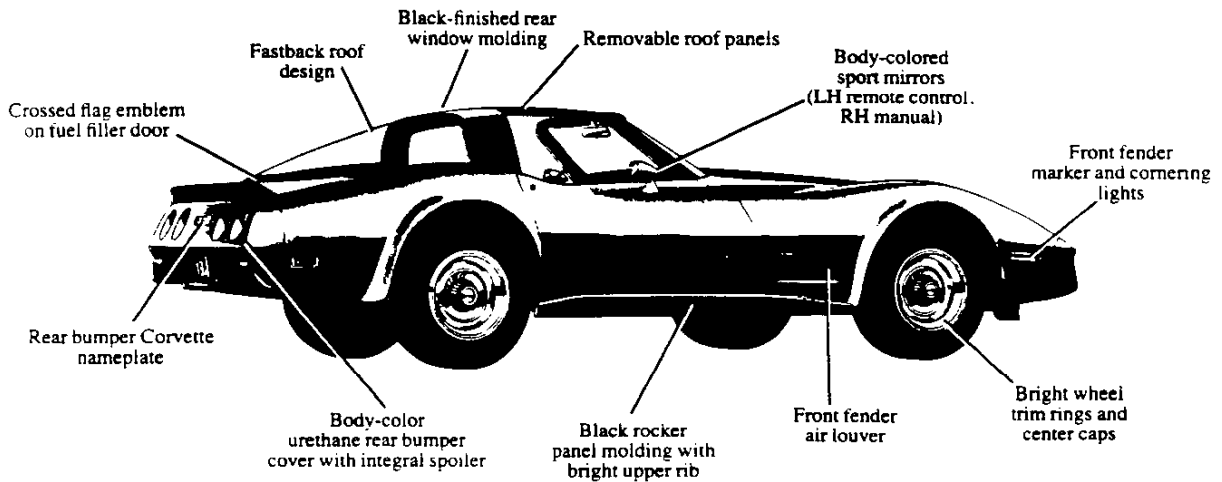
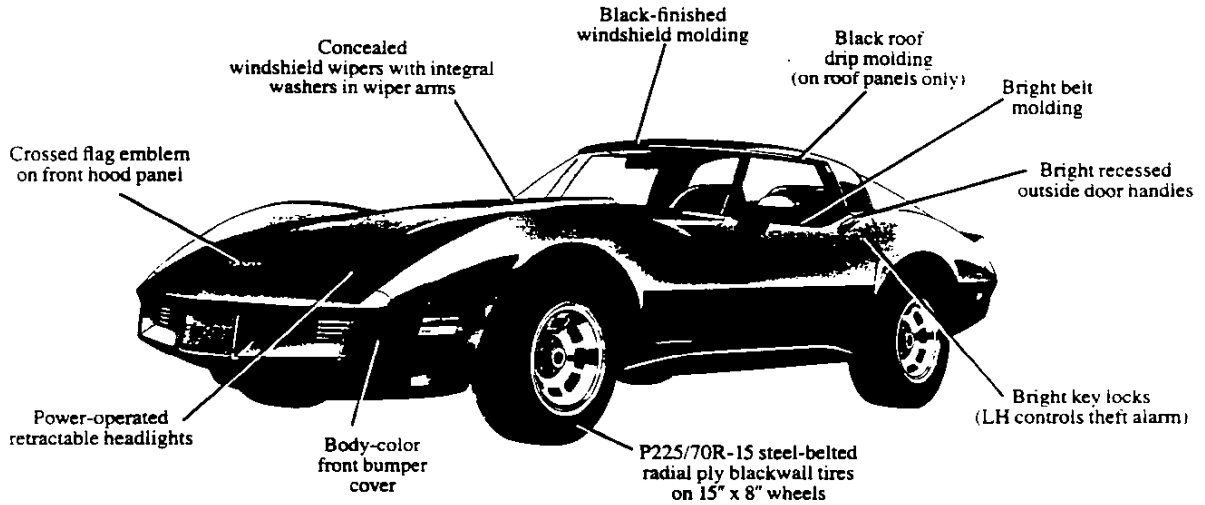

Standard Corvette Bright Trim Rings and Center Caps



Available Aluminum Wheel (RPO N90)

# INTERIOR FEATURES



Corvette Bucket Seats Offered in Choice of Cloth and Vinyl Trim Shown  
(Cloth Cushion and Seat Back Panels) or Leather and Vinyl Trim (Leather Cushion and Seat Back Panels).

## INTERIOR FEATURES

	Corvette
Bucket seats with folding seat backs and inertia seat back locks	S
Forward flat-folding passenger seat back	S
Choice of leather or cloth seat trim on seating surfaces	S
Single loop seat belt system with concealed retractors	S
Color-keyed door trim panels with padded armrests, carpeted lower kick pads, and dual sport mirror controls, and map storage pockets	S
Day/night rearview mirror	S
Visor mirror, illuminated RH	S
Color-keyed coat hook on passenger side	S
Molded headlining with sun visor pockets	S
Center dome light between roof panels, courtesy lights under instrument panel	S
Color-keyed roof panel tie-down straps and black stowage bags	S
Color-keyed carpeting in passenger compartment and rear stowage area	S
Color-keyed floor mats	S
Luggage security shade (black retractable)	S
Additional lockable underfloor stowage behind seats	S
Tinted glass (all windows)	S
Parking brake lever between bucket seats	S

S — Standard

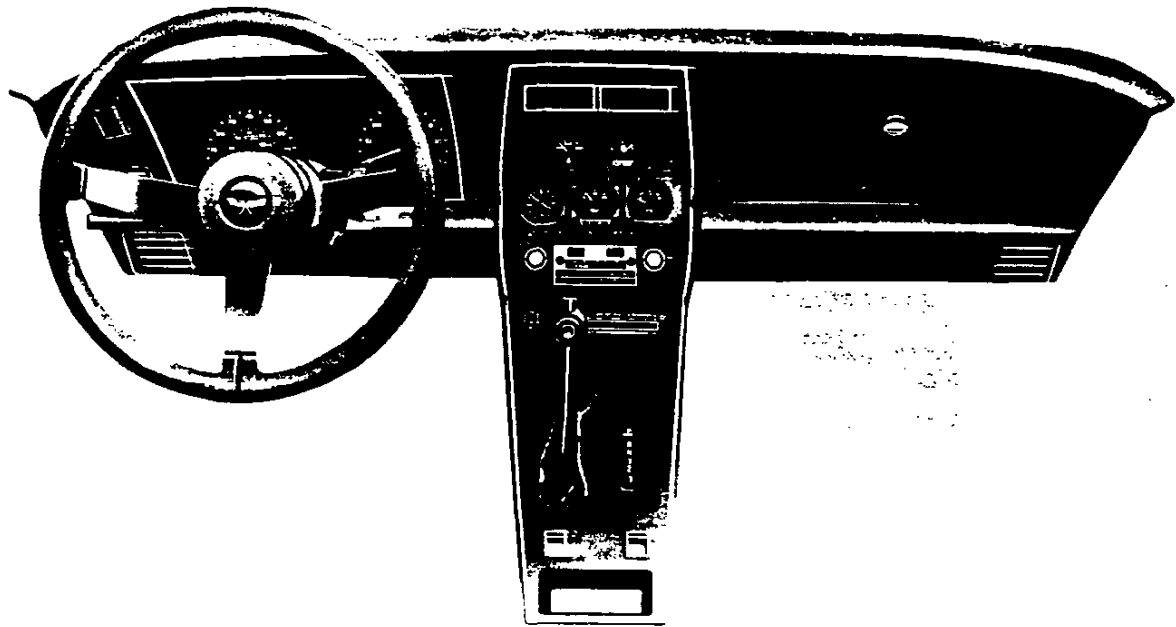

Corvette's Unique Instrument Panel Shown with Available Options.

#### INSTRUMENT PANEL FEATURES

AM/FM radio (may be deleted for credit)	S
Tilt-Telescopic steering column includes color-keyed, leather-wrapped 3-spoke steering wheel	S
Column-mounted lever for turn signal and headlight beam	S
Cigarette lighter in ashtray on console	S
Air conditioning and heater controls on console	S
Power window controls on console	S
Electric clock	S
7000 RPM electronic tachometer	S
Aircraft style voltmeter, temperature, oil pressure and fuel gauges	S
85 mph speedometer with trip odometer	S
Low fuel indicator	S
Headlight-on reminder buzzer	S
Intermittent windshield wiper control	S
Four-speed or automatic transmission with console mounted control	S
Bright accents on dash and console	S
Bright glove compartment door lock	S

S — Standard

## Corvette Color and Trim Combinations

		INTERIOR COLORS						
		BLACK	BEIGE	BLUE	CLARET	RED	GREEN	OYSTER
CORVETTE	Cloth Bucket*	X	X	X	X	X	X	X
	Leather Bucket**	X	X	X	X	X	X	X
EXTERIOR COLOR	CODE							
BEIGE, CORVETTE LIGHT	59	X	X	X	X	X	X	X
BLACK	19	X	X	X	X	X	X	X
BLUE, CORVETTE DARK (MET)	28	X	X	X	X	X	X	X
BROWN, CORVETTE DK (MET)	47	X	X	X	X	X	X	X
CLARET, DARK (MET)	76	X	X	X	X	X	X	X
GREEN, CORVETTE DK (MET)	58	X	X	X	X	X	X	X
RED, CORVETTE	83	X	X	X	X	X	X	X
SILVER, CORVETTE	13	X	X	X	X	X	X	X
WHITE, CLASSIC	10	X	X	X	X	X	X	X
YELLOW, CORVETTE	52	X	X	X	X	X	X	X

\*Cloth seat cushion and seat back panels \*\*Leather seat cushion and seat back panels

See Dealer Order Guide for latest available information.

Corvette/7

# EQUIPMENT SUMMARY

	Corvette Coupe
<b>EXTERIOR</b>	
Front fender vent louvers	S
Front cornering lights	S
Retractable headlights with painted bezels	S
Body color front bumper cover with integral air dam	S
Black painted windshield reveal molding	S
Concealed windshield wipers with integral washers in wiper arms	S
Black rocker panel molding with bright upper rib	S
Rally wheels with bright trim rings and center caps	S
Removable roof panels	S
Black rear window reveal molding	S
Single outboard taillights	S
Single inboard backup lights	S
Body color rear bumper cover with integral spoiler	S
<b>INTERIOR</b>	
Air conditioning	S
Power windows	S
Dual remote Sport mirrors	S
Tilt-Telescopic steering wheel	S
Convenience Group. Includes time-delay dome and courtesy lights, headlight warning buzzer, underhood light, low fuel warning light, color-keyed floor mats, intermittent windshield wipers and RH visor vanity mirror	S
Bucket seats with folding seat backs and inertia seat back locks	S
Forward flat-folding passenger seat back	S
AM/FM radio with fixed length rear-mounted antenna (may be deleted for credit)	S
85-mph speedometer with trip odometer	S
7,000-rpm electronic tachometer	S
Voltmeter, temperature, fuel and oil pressure gages	S
Electric clock	S
Color-keyed instrument panel pad	S
Color-keyed steering wheel and column	S
Day/night rearview mirror	S
Overhead courtesy light	S
Deep-twist floor and stowage area carpet	S
Rear compartment locking storage compartment	S
Acoustical insulation package	S
Luggage compartment security shade	S
<b>POWER TEAMS/CHASSIS/MECHANICAL</b>	
5.7 Liter 4-Bbl. V8 (350 cu. in.) engine, 5.0 Liter 4-Bbl. V8 (305 cu. in.) — California only	S
Automatic or four-speed manual transmission	S
Power steering	S
Recirculating ball steering gear and rear mounted linkage	S
Power disc brakes at all four wheels	S
P225/70R-15B steel-belted radial ply blackwall tires and 15" x 8" wheels	S
Inside hood release	S
Flow-thru ventilation system	S
Delco Freedom battery with side terminals	S
Fully independent front and rear suspension	S
Direct double-acting sealed-unit hydraulic shock absorbers	S
Fiberglass reinforced plastic body	S
Heavy-gage frame structure with corrosion-resistant coating	S
Double-panel door construction	S
S — Standard	

# AVAILABLE OPTIONS

	RPO
<b>Battery, Heavy-Duty</b>	UA1
<b>Carrier, Roof Panel</b>	V54
<b>Chassis Equipment — Trailering.</b> Includes Heavy-Duty Radiator and Gymkhana Suspension. Available only with standard 5.7 Liter or 5.0 Liter V8 and Automatic Transmission	ZN1
<b>Defogger, Electric Rear Window</b>	C49
<b>Door Lock System, Power</b>	AU3
<b>Emission Equipment:</b> See Power Teams for availability	
<b>Standard Emission System</b>	NA5
<b>California Emission Requirements</b>	YF5
<b>Engine:</b> See Power Teams for availability	
<b>5.7 Liter 4-Bbl. V8</b>	L82
<b>Radio Equipment:</b> Includes 30" fixed height rear antenna (except with Power Antenna)	
<b>AM/FM Stereo Radio</b>	U58
<b>AM/FM Stereo/Citizens Band Radio with Power Antenna</b>	UP6
<b>AM/FM Stereo Radio with 8-Track Stereo Tape</b>	UM2
<b>AM/FM Stereo Radio with Stereo Cassette Tape</b>	UN3
<b>Power Antenna, NA with AM/FM Stereo/Citizens Band Radio</b>	U75
<b>Speakers, Dual Rear, NA with AM/FM Radio</b>	U81
<b>Roof Panels, Removable Glass.</b> Twin removable tinted glass panels	CC1
<b>Speed Control, Automatic.</b> Requires Automatic Transmission	K30
<b>Suspension Equipment:</b>	
<b>Gymkhana.</b> Includes larger diameter rear stabilizer and bushings, higher capacity springs and special shock absorbers	FE7
<b>Shock Absorbers, Heavy-Duty, NA with Trailering Equipment or Gymkhana Suspension</b>	F51
<b>Tires:</b>	
<b>P225/70R-15 Steel-Belted Radial Ply White Lettered</b>	QGR
<b>P255/60R-15 Steel-Belted Radial Ply White Lettered</b>	QBS
<b>Transmissions:</b> See Power Teams for availability	
<b>Four-Speed Manual.</b> Available at no extra charge	MM4
<b>Automatic.</b> Available at no extra charge	MX1
<b>Trim, Interior:</b> (See Color and Trim Selections)	
<b>Cloth Bucket Seat Interior.</b> Available at no extra charge	---
<b>Leather Bucket Seat Interior.</b> Available at no extra charge	---
<b>Wheels, Aluminum</b>	N90

NA — Not Available

See Options Section for Additional Details and Illustrations.

Corvette/9

# POWER TEAMS

Engine	RPO No.	Power Rating*	Displacement (cubic inches)	Engine Availability	Transmissions/Rear Axle Ratios	
					Four-Speed Manual RPO MM4 (1) Std.	Automatic RPO MX1 (1) (2)

## ALL STATES EXCEPT CALIFORNIA

(with Standard Emission System — RPO NA5)

5.7 Liter 4-Bbl. V8 (A)	L48	190	350	Std.	3.07	3.07
5.7 Liter 4-Bbl. V8 (A)	L82	230	350	EC	3.07	3.07

## CALIFORNIA ONLY

(with California Emission Requirements — RPO YF5)

5.0 Liter 4-Bbl. V8 (B)	LG4	180	305	Std.	—	3.07
-------------------------	-----	-----	-----	------	---	------

\*S.A.E. net horsepower as installed. Std. — Standard. EC — Available at extra cost.

(1) With console-mounted shift control.

(2) Available in place of standard Four-Speed Manual Transmission at no extra cost.

(A) Produced by GM — Chevrolet Motor Division.

(B) Produced by GM — Chevrolet Motor Division and GM of Canada Engine Plants.

See EPA section for mileage estimates.

# BODY/CHASSIS FEATURES

Standard On 1980 Corvette

## Body Structure & Features

- Molded fiberglass reinforced body construction
- Heavy-gage frame structure with corrosion-resistant coating
- Corrosion-resistant steel-reinforced fiberglass body
- Energy-absorbing honeycomb cushion front bumper system
- Energy-absorbing rear bumper system with twin hydraulic shock absorbers
- Double-panel door construction
- Protective fiberglass front fenders
- Tinted glass
- Anti-theft audio alarm system
- Luggage area security shade
- Single lever roof panel locks
- Concealed dual-speed electric windshield wipers
- Durable acrylic finish

## Chassis Features

- Power steering helps make parking and maneuvering in city traffic easy
- Power disc brakes at all four wheels
- Automatic transmission or Four-speed fully synchronized manual transmission
- Delcotron generator with built-in solid-state regulator
- High Energy Ignition system
- Coolant recovery system
- Exhaust valve rotators on all engines

- Hydraulic valve lifters
- Long recommended service intervals for oil change, oil filter, spark plugs, chassis lubrication and automatic transmission fluid
- Delco Freedom battery never needs refilling. Sealed side terminals help prevent corrosion buildup
- Front stabilizer bar to help control sway
- Limited slip rear axle
- Recirculating ball steering gear with rear mounted linkage
- Fully independent front and rear suspension
- Temperature-controlled engine radiator fan
- Early Fuel Evaporation system on all engines to hasten engine warm-up
- Tires incorporate tread wear indicator
- Direct double-acting sealed-unit hydraulic shock absorbers
- P225/70R-15 steel-belted radial ply blackwall tires and 15" x 8" wheels

## Exterior Body Preparation and Paint Processes

1. Dry sand exterior body surfaces, then vacuum to remove dust.
2. Clean all surfaces with solvent.
3. Apply red rubbing putty to fill surfaces, then vacuum to

remove excess putty.

4. Spray prime all exterior surfaces.
5. Bake 45 minutes at 275° F.
6. Glaze where necessary with gray putty.
7. Water sand exterior and interior surfaces and dry.
8. Glaze where necessary with gray putty.
9. Spray all exterior and interior surfaces with sealer and dry.
10. Spray acrylic finish over exterior surfaces and air dry for 3 minutes minimum (first finish coat).
11. Bake 30 minutes at 180° F.
12. Cool to room temperature and fill any minor imperfections with resin.
13. Wet sand and fill remaining imperfections with gray putty where necessary, then vacuum body.
14. Spray dark gray primer on any surfaces oversanded.
15. Repeat operation # 10 (for second finish coat).
16. Repeat operation # 10 (for third finish coat).
17. Bake 30 minutes at 180° F and cool to room temperature.
18. Mask off and spray specific areas with black finish.
19. Machine sand using mineral spirits liberally as lubricant.
20. Machine polish body to a high lustre.



# DIMENSIONS/ SPECIFICATIONS

## EXTERIOR DIMENSIONS

Wheelbase	98.0
Length (overall)	185.3
Width (overall)	69.0
Height (loaded)	48.0
Front tread	58.7
Rear tread	59.5
Minimum ground clearance	4.3

## INTERIOR ROOMINESS

Head room	36.2
Leg room	42.1
Hip room	49.9
Shoulder room	47.5

## LUGGAGE COMPARTMENT

Usable luggage space (cu. ft.)	8.4
--------------------------------	-----

## FUEL TANK CAPACITY (gallons)

	24.0
--	------

## CURB WEIGHT (pounds)

	3334
--	------

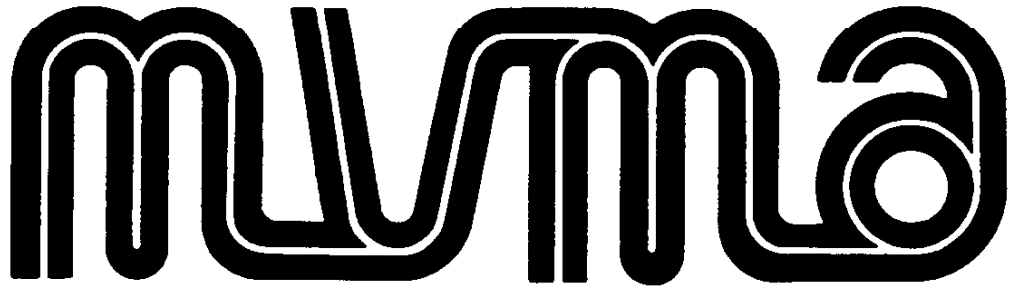

**Specifications  
Form  
Passenger Car**

**1980**

**METRIC (U.S. Customary)**

<b>Manufacturer</b> CHEVROLET MOTOR DIVISION GENERAL MOTORS CORPORATION	<b>Car Line</b> CORVETTE	
<b>Mailing Address</b> CHEVROLET ENGINEERING CENTER 30003 VAN DYKE WARREN, MICHIGAN 48090	<b>Model Year</b> 1980	<b>Issued:</b> Oct. 1979
		<b>Revised (*)</b> Feb. 1980

The information contained herein is prepared, distributed by, and is solely the responsibility of the automobile manufacturing company to whose products it relates. Questions concerning these specifications should be directed to the manufacturer whose address is shown above. This specification form was developed by automobile manufacturing companies under the auspices of the Motor Vehicle Manufacturers Association of the United States, Inc.

The General Specifications herein are those in effect at date of compilation and are subject to change without notice by the manufacturer.

---

**MVMA Specifications Forms**  
**Passenger Car**  
**METRIC (U.S. Customary)**

**Table of Contents**

---

1	Car Models
2	Power Teams
3-7	Engine
7	Exhaust System
8	Fuel System
9	Cooling System
10, 11	Vehicle Emission Control
12-14	Electrical
15-17	Drive Units
18	Tires and Wheels
18, 19	Brakes
20	Steering
21	Suspension — Front and Rear
22	Body — Miscellaneous Information
22	Frame
23	Convenience Equipment
24	Vehicle Mass (Weight)
25	Optional Equipment Mass (Weight)
26-30	Car and Body Dimensions — including Fiducial Marks, Glass, Lamps and Headlamp Shape
31-35	Car and Body Dimension Key Sheets
36	Index

---

**NOTE:**

1. This form uses both SI metric units and U.S. Customary units. The Metric unit of measurement is presented first, and the U.S. Customary unit follows in parentheses.
2. **UNLESS OTHERWISE INDICATED:**
  - a. Specifications apply to standard models without optional equipment. Significant deviations are noted.
  - b. Nominal design dimensions are used throughout these specifications.
  - c. All linear dimensions are in millimeters (inches), and all mass (weight) specifications are in kilograms (pounds).
3. The General Specifications herein are those in effect at date of completion and are subject to change without notice by the manufacturer.
4. A printed or computer tape supplement containing additional Car and Body Dimensions and/or drawings (based in part on SAE J1100a "Motor Vehicle Dimensions") may be available from the manufacturer.

**MVMA Specifications Form**  
**Passenger Car**  
**METRIC (U.S. Customary)**

Car Line CORVETTE  
 Model Year 1980 Issued 10/79 Revised (\*) \_\_\_\_\_

U. S. Customary Units Only.

**Car Models**

Model Description (Include Line Drawings of Vehicles, if Desired)	Make, Car line, Series, Body Type (Mfg.'s Model Code)	No. of Designated Seating Positions (Front/Rear)	Max. Trunk/Cargo Load — Kilograms (Pounds)
<u>CORVETTE</u> 2-Door Sport Coupe	<u>MODEL NUMBER</u> 1YZ87	<u>FRONT</u> 2	

**NOTE:** Any specifications on the following pages that are specific to California requirements are indicated accordingly.

**MVMA Specifications Form**  
**Passenger Car**  
**METRIC (U.S. Customary)**

Car Line CORVETTE  
 Model Year 1980 Issued 10/79 Revised (\*) \_\_\_\_\_

U. S. Customary Units Only.

**Power Teams** (Indicate whether standard or optional)

SAE Net bhp (brake horsepower) and net torque corrected to 85° F and 29.38 in. Hg atmospheric pressure.

SERIES # AVAILABILITY	ENGINE						TRANSMISSION	AXLE RATIO (Std first) (:1) (Indicate A/C ratio)	
	Displ. liters (in <sup>3</sup> )	Carb.	Compr. Ratio	SAE Net at RPM		Exhaust System*		A	B
				kW (bhp)	Torque N·m (lb. ft.)				
Base - All Exc. Calif.	5.7 (350) RPO L48	4-bb1	8.2:1	190 @ 4400	280 @ 2400	D	Man. 4-Spd. - Base 2.88 Low	3.07	-
							Auto 3-Spd. '350c' Available	3.07	-
Avail. - All Exc. Calif.	5.7 (350) RPO L82	4-bb1	9.0:1	230 @ 5200	275 @ 3600	D	Auto 3-Spd. '350c' Available	3.07	-
Avail. - Calif Only	5.0 (305) RPO LG4	4-bb1	8.6:1	180 @ 4200	255 @ 2000	D	Auto 3-Spd. '350' Available (Ⓢ)	3.07	-
<p># - 'Base' and 'Available' refer to engine availability.            A - Base - all states.            B - Optional - all states.</p> <p>Limited slip differential standard equipment for all axle ratios.            Air conditioning available with all axle ratios.</p> <p>(Ⓢ) - 310 mm (12.2 in.) converter.</p>									

\*S - Single D - Dual

**MVMA Specifications Form**  
**Passenger Car**  
**METRIC (U.S. Customary)**

Car Line CORVETTE  
 Model Year 1980 Issued 10/79 Revised (\*) \_\_\_\_\_

U. S. Customary Units Only.

Engine Description / Carb.

5.0 Liter V-8/4-bbl (305 CID) RPO LG4	5.7 Liter V-8/4bbl (350 CID)	
	RPO L48	RPO L82

**Engine — General**

*Total dressed engine mass (wt) dry	537.7	540.1	539.0
Type (In-line, V and Angle, Flat)	90°V, Front		
Location (Front, Mid, Rear)	90°V, Front		
No. of cylinders	8		
Bore	3.736	4.0	
Stroke	3.48		
Piston Displacement cm <sup>3</sup> (in <sup>3</sup> )	305	350	
Bore Spacing (C/L to C/L)	4.40		
Cyl No. system (front to rear)**	L Bank	1-3-5-7	
	R Bank	2-4-6-8	
Firing Order	1-8-4-3-6-5-7-2		
Cylinder Head Material	Cast iron		
Cylinder Block Material	Cast iron		
Cylinder block deck height	9.03		
Number of mtg. points	Front	Two	
	Rear	One	
Engine installation position (transverse, Longitudinal)	Longitudinal		
Recommended fuel Leaded, unleaded	Unleaded		
Fuel antiknock index (R + M) 2	87		
Cylinder Head Volume — cm <sup>3</sup>	58.9	75.47	
Head Gasket Thickness (Compressed)	.021		
Head Gasket Volume — cm <sup>3</sup>	4.60		
Deck clearance (minimum) (above or below block)	.025 (below)		
Minimum Combustion Chamber Volume — cm <sup>3</sup>	56.7	73.27	

**Engine — Pistons**

Material		Cast aluminum	Forged aluminum
Description and finish		Closed skirt, sump head	Closed skirt, flat head
Mass. g (weight, oz.) — Piston Only		17.92	21.31
Clearance (limits)	Top land	.0245-.0335	.0235-.0325
	Skirt	Top	.0007-.0042
		Bottom	.0007-.0017
Ring groove diameter	No. 1 ring	3.320-3.335	3.541-3.556
	No. 2 ring	3.320-3.335	3.541-3.556
	No. 3 ring	3.300-3.315	3.577-3.592

\*Dressed engine mass (weight) includes the following:

Ready to run - front of engine to rear of engine block, less radiator hoses, coolant, accelerator controls and engine mountings.

\*\* Rear of engine - drive takeoff.

View from drive takeoff end to determine left & right side of engine.

**MVMA Specifications Form**  
**Passenger Car**  
**METRIC (U.S. Customary)**

Car Line CORVETTE  
 Model Year 1980 Issued 10/79 Revised (\*) \_\_\_\_\_  
U. S. Customary Units Only.

Engine Description/Carb.	5.0 Liter V-8/4-bbl (305 CID) RPO LG4	5.7 Liter V-8/4-bbl (350 CID)	
		RPO L48	RPO L82

**Engine — Piston Rings**

Function (top to bottom)	No. 1, oil or comp.	Compression		
	No. 2, oil or comp.	Compression		
	No. 3, oil or comp.	Oil		
Compression	Description — Upper	Radius face, .0004" chrome flash		Radius face, moly-channel
	Material, coating, etc. Lower	Reverse twist, tapered face, lubrited		
	Width	(a)	(b)	(c)
Oil	Gap	Upper - .010-.020; Lower - .013-.025		
	Description — material, coating, etc.	TRW T-flex design .002" minimum chrome	Stainless steel - 50 .002" minimum chrome	Stainless steel - 50 .006" minimum chrome
	Width	.1859-.1879	.185-.187	
Expanders	Gap	.010-.035		
		In oil ring assembly		

**Engine — Piston Pins**

Material	Chromium steel (1018)		
Length	2.990-3.010		
Diameter	.9270-.9273		
Type	Locked in rod, in piston, floating, etc.	Locked in rod	
	Bushing In rod or piston Material	None	
Clearance	In piston	.00025-.00035	.00045-.00055
	In rod	---	
Direction & amount offset in piston	Major thrust side - .060		None

**Engine — Connecting Rods**

Material	1037 or 1038 steel		
Mass, g (weight, oz.)	13.69	20.81	
Length (center to center)	5.695-5.705		
Bearing	Material & Type	Premium aluminum	
	Overall length	.797	
	Clearance (limits)	.0013-.0035	
	End Play	.006-.016	

- (a) Upper - .0770-.0780; Lower - .0775-.0780
- (b) Upper - .0775-.0780; Lower - .0770-.0775
- (c) Upper & Lower - .0770-.0775

**MVMA Specifications Form**  
**Passenger Car**  
**METRIC (U.S. Customary)**

Car Line CORVETTE  
 Model Year 1980 Issued 10/79 Revised (•) \_\_\_\_\_

U. S. Customary Units Only.

Engine Description/Carb.

5.0 Liter V-8/4-bbl (305 CID) RPO LG4	5.7 Liter V-8/4-bbl (350 CID)	
	RPO L48	RPO L82

**Engine — Crankshaft**

Material	Nodular cast iron		Forged steel	
Vibration damper type	Rubber mounted inertia			
End thrust taken by bearing (No.)	5			
Crankshaft end play	.002-.007			
Main bearing	Material & type	#1-G66 conecc; #2,3,4-Premium aluminum; #5 upper-M100; #5 lower W/A.T. - M400; #5 lower W/M.T. - M100		
	Clearance	#1 - .008-.0020; #2,3,4 - .0011-.0023; #5 - .0017-.0033		
	Journal dia. and bearing overall length	No. 1	2.4489 x .802	
		No. 2	2.4486 x .802	
		No. 3	2.4486 x .802	
		No. 4	2.4486 x .802	
		No. 5	2.4484 x 1.533	
		No. 6	---	
No. 7	---			
Dir. & amt. cyl. offset	---		---	
No. bolts/main brg. cap	2		4	
Crankpin journal diameter	2.099-2.100			

**Engine — Camshaft**

Location	In block above crankshaft			
Material	Cast alloy iron			
Bearings	Material	Steel backed babbitt		
	Number	5		
Type of Drive	Gear, chain or belt	Silent chain		
	Crankshaft gear or sprocket material	Sintered iron		
	Camshaft gear or sprocket material	Aluminum nylon		
	Timing chain	No. of links	46	
		Chain or Belt	Width	.625
			Pitch	.500



**MVMA Specifications Form**  
**Passenger Car**  
**METRIC (U.S. Customary)**

Car Line CORVETTE  
 Model Year 1980 Issued 10/79 Revised (\*) \_\_\_\_\_

U. S. Customary Units Only.

Engine Description/Carb.

5.0 Liter V-8/4-bbl (305 CID) RPO LG4	5.7 Liter V-8/4-bbl (350 CID)	
	RPO L48	RPO LB2

**Engine — Valve System**

Hydraulic lifters (Std., opt., NA)		Standard				
Valve rotator, type (intake, exhaust)		Exhaust				
Push rods (dia., length, material)		.3125; 7.724; welded steel tubing, carbonitrited				
Rocker ratio		1.50:1				
Operating tappet clearance (indicate hot or cold)	Intake	Zero				
	Exhaust	Zero				
Timing (based on top of ramp points)	Intake	Opens (*BTC)	28	28	52	
		Closes (*ABC)	64	72	114	
		Duration (deg.)	272	280	346	
	Exhaust	Opens (*BBC)	78	78	98	
		Closes (*ATC)	30	30	62	
		Duration (deg.)	288	288	340	
	Valve open overlap (deg.)		58	58	114	
Intake Valve	Material (a)		21-2N steel, (c)	SAE 1541 - H. forged steel		
	Overall length		4.912	4.880		
	Actual overall head dia.		1.84	1.940	1.940	
	Angle of seat & face (deg.)		46, 45			
	Seat insert material		None			
	Stem diameter		.3410-.3417			
	Stem to guide clearance		.0010-.0027			
	Lift (at zero lash)		.357	.390	.450	
	Outer Spring press & length	Valve closed — N at mm (lb. at in.)	76-84 @ 1.70			
		Valve open — N at mm (lb. at in.)	175 @ 1.25	180-188 @ 1.25	196-204 @ 1.25	
	Inner spring press & length	Valve closed — N at mm (lb. at in.)	Spring damper			
		Valve open — N at mm (lb. at in.)	Spring damper			
	Exhaust Valve	Material (a)		21-2N steel, aluminized head		
		Overall length		4.910	4.920	4.900
Actual overall head dia.		--	1.50			
Angle of seat & face (deg.)		46, 45				
Seat insert material		None				
Stem diameter		.3410-.3417				
Stem to guide clearance		.0010-.0027				
Lift (at zero lash)		.390	.410	.460		
Outer spring press & length		Valve closed — N at mm (lb. at in.)	76-84 @ 1.70			
		Valve open — N at mm (lb. at in.)	184 @ 1.16	186-194 @ 1.16	197-209 @ 1.25	
Inner spring press & length	Valve closed — N at mm (lb. at in.)	Spring damper				
	Valve open — N at mm (lb. at in.)	Spring damper				

(a) RPO LG4 & L48 - chrome flash stem; RPO LB2 - full chrome stem.

Page 6 (c) Full chrome.

**MVMA Specifications Form**  
**Passenger Car**  
**METRIC (U.S. Customary)**

Car Line CORVETTE  
 Model Year 1980 Issued 10/79 Revised (\*)

U. S. Customary Units Only.

Engine Description/Carb.

5.0 Liter V-8/4-bb1 (305 CID) RPO LG4	5.7 Liter V-8/4-bb1 (350 CID)	
	RPO L48	RPO L82

**Engine — Lubrication System**

Type of lubrication (splash, pressure, nozzle)	Main bearings	Pressure
	Connecting rods	Pressure
	Piston pins	Splash
	Camshaft bearings	Pressure
	Tappets	Pressure
	Timing gear or chain	Centrifugally oiled from camshaft bearing
	Cylinder walls	Pressure jet cross sprayed
Oil pump type	Gear	
Normal oil pressure-kPa (Psi) at engine rpm	45 @ 2000	
Type oil intake (floating, stationary)	Stationary	
Oil filter system (full flow, part, other)	Full flow	
Capacity of cr/case, less filter-refill-L (qt.)	4.0	
Oil grade recommended (SAE viscosity and temperature range)	20°F & above - 20W-20, 10W-30, 10W-40, 20W-40, 20W-50 0 to 60°F - 10W, 5W-30, 10W-40, 10W-30 20°F and below - 5W-20, 10W-30	
Engine service reqmt. (SD, SE, etc.)	SE	

**Engine — Exhaust System**

Type (single, single with cross-over, dual, other)	Dual	
Muffler No. & Type (reverse flow, straight thru, separate resonator)	Two, reverse flow	
Resonator No. & type	None	
Exhaust Pipe	Branch O.D., wall thickness	2.5 x .071
	Main O.D., wall thickness	2.5 x .071
	Material	Laminated stainless steel tubing
Intermediate Pipe	O.D. & wall thickness	2.5 x .072
	Material	Laminated stainless steel tubing
Tail Pipe	O.D. & wall thickness	2.0 x .062
	Material	Welded or seamless steel tubing, Aluminized

**MVMA Specifications Form**  
**Passenger Car**  
**METRIC (U.S. Customary)**

Car Line CORVETTE  
 Model Year 1980 Issued 10/79 Revised (\*) 2/80

U. S. Customary Units Only.

Engine Description/Carb.

5.0 Liter V-8/4-bbl (305 CID) RPO LG4	5.7 Liter V-8/4-bbl (350 CID)	
	RPO L48	RPO L82

**Engine — Fuel System** (See supplemental page for Details of Fuel Injection, Supercharger, Turbocharger, etc. if used)

Inductions type: Carburetor, fuel injections, etc.		Carburetor		
Fuel Tank	Refill capacity — L (U.S. gals.)	24 (approximately)		
	Filler location	Center of rear deck		
Fuel Pump	Type (elec. or mech.)	Mechanical		
	Locations	Lower R.F. of engine		
	Pressure range — kPa (psi)	7.5-9.0		
Fuel Filter	Type	Fine mesh plastic strainer in gasoline tank & paper filter element in carburetor inlet		
	Locations			
Carburetor	Choke type			
	Intake manifold heat control (exhaust or water)	Exhaust		
	Air cleaner type	Standard	Replaceable paper element, single snorkel	
		Optional		
	Idle spd. rpm (spec. neutral or drive)	Manual	--	700/N
Propane (Neu.)				
Automatic		650/D	500/D	
Propane (Neu.)				
Idle A/F mix.				

**Carburetor Supplementary Information**

Model Usage	Engine Displ. — L (in.³)	Transmission	Carburetors		No. Used and Type	Barrel Size
			Make	Model		
All	350 (RPO L48)	Manual	Rochester	17080207	One, 4-bbl	Pri-1.38 Sec-2.25
		Automatic		17080204		
	Automatic	17080223				
	350 (RPO L82)	Automatic		(17080517)		
	305 (RPO LG4)	Automatic				
Data in brackets ( ) pertains to California.						

**MVMA Specifications Form**  
**Passenger Car**  
**METRIC (U.S. Customary)**

Car Line CORVETTE  
 Model Year 1980 Issued 10/79 Revised (\*) \_\_\_\_\_

U. S. Customary Units Only.

Engine Description / Carb.	5.0 Liter V-8/4-bb1 (305 CID) RPO LG4	5.7 Liter V-8/4-bb1 (350 CID) RPO L48	RPO LB2

**Engine — Cooling System**

Coolant recovery system (std., opt., none)		Standard	
Radiator cap relief valve pressure — kPa (psi)		15	
Circulation thermostat	Type (choke, bypass)	Choke	
	Starts to open at °C (°F)	195	
Water pump	Type (centrifugal, other)	Centrifugal	
	GPM 1000 pump rpm		
	Number of pumps	One	
	Drive (V-belt, other)	V-belt	
Bearing Type		Permanently lubricated double row ball	
By-pass recirculation type (inter., ext.)		Internal	
Radiator core type (cross-flow, vertical, cellular, tube and fin, other)		Cross-flow, tube and center	
Cooling System Capacity	With heater — L (qt.) (*)	21.52	21.60
	Without heater — L (qt.)	Base equipment	
	Opt. equipment—specify — L (qt.) (b)	22.88	21.60
Water jackets full length of cyl. (yes, no)		Yes	
Water all around cylinder (yes, no)		Yes	
Radiator hose	Lower	Number and type (molded, straight)	One, molded
		Inside diameter	1.50 1.75
	Upper	Number and type (molded, straight)	One, molded
		Inside diameter	1.50
	By-pass	Number and type (molded, straight)	None
		Inside diameter	
Radiator (Core)	Standard	Width	26.3
		Height	16.89 16.97
		Thickness	1.58 2.68
	A/C	Width	26.3
		Height	16.89 16.97
		Thickness	1.58 2.68
	Heavy duty	Width	---
		Height	---
		Thickness	---
Fan (Standard)	Number of blades & spacing		5
	Diameter		17.5
	Ratio — fan to crankshaft rev.		1.25:1 1.13:1
	Fan cutout type		Thermomodulated viscous type clutch
	Drive Type-Number of Fans		V-belt - one
Fan (optional)	No. of blades and spacing		7
	Diameter		18.5
	Ratio — fan to crankshaft rev.		1.25:1 1.13:1
	Fan cut-out type		Thermomodulated viscous type clutch
	Drive Type-Number of Fans		V-belt - (1) V-belt & electric-(2)(A)

- (A) Thermostatically controlled remote control electric fan used with air conditioning.
- (\*) Base transmission.
- (b) With air conditioning.

**MVMA Specifications Form**  
**Passenger Car**  
**METRIC (U.S. Customary)**

Car Line CORVETTE  
 Model Year 1980 Issued 10/79 Revised (\*) \_\_\_\_\_

U. S. Customary Units Only.

Engine Description/Carb.

5.0 Liter V-8/4-bb1 (305 CID) RPO LG4	5.7 Liter V-8/4-bb1 (350 CID)	
	RPO L48	RPO L82

**Vehicle Emission Control**

Calif. only

49 States (all exc. Calif.)

Type (Air injection, engine modifications other)	Air Injection		Air Injection
	Air Injection Pump	Type	w/C-4 System
Displacement — cm <sup>3</sup> (in <sup>3</sup> )		(Computer	
Drive ratio		Controlled	
Drive type		Catalytic	
Relief valve (type)		Converter)	
Filter (describe)			
Air Injection System	Air distribution (head, manifold, etc.)		
	Point of entry		
	Injection tube i.d.		
	Check valve type		
Exhaust Gas Recirculation System	Backfire protection (type)		
	Type (controlled flow, open orifice, other)	Controlled Flow	
	Valve type	Vacuum modulated shut-off & metering valve	
	Valve location	Right rear at manifold	
	Control energy source	Carburetor vacuum	
	Exhaust source	Manifold exhaust crossover	
	Exhaust cooler type	None	
Catalytic Converter System	Orifice no. and size	One; 0.030	
	Point of exhaust injection (spacer, carburetor, manifold, other)	Inlet Manifold	
	Catalyst	Type	Platinum - Palladium
Volume — L (in <sup>3</sup> )		4.3 (260)	
Substrate type	Bead		
	Container location	Beneath underbody, below passenger seat	
Other	Carburetor	Hot	
	Air	Thermostatically controlled air cleaner inlet valve regulates and mixes heated air with incoming cold air to reduce carbon emission	

**MVMA Specifications Form**  
**Passenger Car**  
**METRIC (U.S. Customary)**

Car Line CORVETTE  
 Model Year 1980 Issued 10/79 Revised (\*) \_\_\_\_\_  
U. S. Customary Units Only.

Engine Description/Carb.

5.0 Liter V-8/4-bbl (305 CID) RPO LG4 Calif. Only	5.7 Liter V-8/4-bbl (350 CID) RPO L48 49 States (All Exc. Calif.)	RPO LB2
---	---	---------

**Vehicle Emission Control (Continued)**

Crankcase Emission Control	Type (ventilates to atmos., induction system, other)		Standard	Induction system	
			Optional	---	
	Control Unit	Make and model		A.C.	
		Location		Left front rocker cover	
		Energy source (manifold vacuum, carburetor, other)			
		Energy source (manifold) vacuum, carburetor, other)		Manifold vacuum	
	Complete System	Control method (variable orifice, fixed orifice, other)		Variable orifice	
		Discharges (to intake manifold, other)		Intake manifold	
		Air inlet (breather cap, other)		Carburetor air inlet	
	Evaporative Emission Control	Flame arrestor (screen, other)		Screen	
Fuel Tank		Thermal expansion volume — $dm^3$ ( $ft^3$ )		Approximately 10% of refill capacity	
		Relief Pressure kPa (psi) and location			
		Vacuum relief kPa (psi) and location			
		Vapor-liquid separator type		Integral with fuel tank	
		Vapor vented to (crankcase, canister, other)		Canister	
Carbu- etor		Vapor vented to (crankcase, canister, other)		---	
Vapor Storage		Storage provision (crankcase, canister, other)		Canister	
		Volume — $dm^3$ ( $ft^3$ ) or capacity (grams)		Approximately 50 grams storage capacity	
	Control valve type		Controlled by orifices and carburetor throttle body and throttle blade position.		

**MVMA Specifications Form**  
**Passenger Car**  
**METRIC (U.S. Customary)**

Car Line CORVETTE  
 Model Year 1980 Issued 10/79 Revised (\*) \_\_\_\_\_

U. S. Customary Units Only.

Engine Description/Carb.	5.0 Liter V-8/4-bb1 (305 CID) RPO LG4	5.7 Liter V-8/4-bb1 (350 CID) RPO L48	RPO L82

**Electrical — Supply System**

Battery	Make and Model	Delco Remy 'Freedom'		
	Voltage Rtg — V — & Total Plates	12V-3500 watts		
	SAE Designation No. and/or capacity	100 minute reserve capacity		
	Location	Storage compartment behind driver		
Generator or Alternator	Make	Delco Remy		
	Model	1103122		
	Type and rating	Diode rectified - 63		
	Output at engine idle (neutral) A			
	Ratio — Gen. to Cris rev.	3.17:1	2.73:1	
Regulator	Make	Delco Remy		
	Model	---		
	Type	Micro circuit unit integral with alternator		
	Regulated	Voltage	13.8-14.8	
		Current A		
	Voltage test conditions	Temperature — °C (°F)	Operating	
Load A		3-8		
Other		None		

**Electrical — Starting System**

Starting Motor	Make	Delco Remy		
	Model	1998217	1109067-M/T(a)	1998217 A/T
Motor Drive	Engagement Type	Positive shift solenoid		
	Pinion engages from (front, rear)	Rear		
	Number of teeth	Pinion	9	
		Flywheel	Manual	153
Auto	168			

(a) Auto. trans. - 1998217

**MVMA Specifications Form**  
**Passenger Car**  
**METRIC (U.S. Customary)**

Car Line CORVETTE  
 Model Year 1980 Issued 10/79 Revised (\*) 2/80

U. S. Customary Units Only.

Engine Description/Carb.

5.0 Liter V-8/4-bb1  
 (305 CID) RPO LG4

5.7 Liter V-8/4-bb1 (350 CID)  
 RPO L48 RPO L82

**Electrical — Ignition System — Distributor**

Distributor	Manual	---	1103287	---
	Automatic	(1103363)	1103353	1103435
Timing	Manual	---	8° BTC	
	Automatic	(4° BTC)	6° BTC	° BTC

Distributor Model	CENTRIFUGAL ADVANCE Crankshaft Degrees at Engine RPM			VACUUM ADVANCE Crankshaft Deg. at kPa (in. of Hg.)	
	Start	Intermediate	Maximum	Start	Maximum
1103369	0 @ 1000	10 @ 1700	20 @ 3800	0 @ 4	10 @ 8
1103287	0 @ 1200	12 @ 2000	22 @ 4200	0 @ 6	15 @ 12
1103353	0 @ 1100	12 @ 1600	22 @ 4600	0 @ 4	20 @ 10
1103435	0 @ 1100	12 @ 1600	22 @ 4600	0 @ 3	16 @ 6.5



**MVMA Specifications Form**  
**Passenger Car**  
**METRIC (U.S. Customary)**

Car Line CORVETTE  
 Model Year 1980 Issued 10/79 Revised (\*) 2/80

U. S. Customary Units Only.

Engine Description/Carb.

5.0 Liter V-8/4-bb1 (305 CID) RPO LG4	5.7 Liter V-8/4-bb1 (350 CID)	
	RPO L48	RPO L82

**Electrical — Ignition System**

Type	Conventional — Std., Opt., N.A.		---
	Transistorized — Std., Opt., N.A.		---
	Other (specify)		H.E.I. (High Energy Ignition)
Coil	Make		Delco Remy
	Model		Integral with distributor cap
	Current	Engine stopped — A	---
		Engine idling — A	---
Spark Plug	Make		AC Spark Plug
	Model		R45TS
	Thread (mm)		14
	Tightening torque — N-m (lb. ft.)		25
	Gap		.045

**Electrical — Suppression**

Locations & type	
------------------	--

**Electrical — Instrument and Equipment**

Speedometer	Type	Circular dial with pointer
	Trip odometer (std., opt., N.A.)	Standard
EGR maintenance indicator		NA
Charge Indicator	Type	Voltmeter
	Warning device	Generator warning lamp
Temperature Indicator	Type	Electric gauge
	Warning device	NA
Oil pressure Indicator	Type	Electric gauge
	Warning device	NA
Fuel Indicator	Type	Electric gauge
	Warning device	Low fuel warning lamp
Windshield Wiper	Type — standard	Electric, two-speed intermittent system standard
	Type — optional	None
	Blade length	16.0 inch
	Swept area — cm <sup>2</sup> (in. <sup>2</sup> )	667.0
Windshield Washer	Type — standard	Pushbutton - manual
	Type — optional	None
	Fluid level indicator	NA
Horn	Type	Vibrator
	Number used	Two
	Current draw (A) per horn	4.5-6.5 @ 12.5 volts
Other	Tachometer/anti-theft alarms; parking brake warning light and brake failure warning lights; restraint system warning light and buzzer. "CHOKE" warning lamp in tach "CHECK ENGINE" warning lamp - in center console (Calif. c Halogen high beam (inner) headlamps standard	

**MVMA Specifications Form**  
**Passenger Car**  
**METRIC (U.S. Customary)**

Car Line CORVETTE  
 Model Year 1980 Issued 10/79 Revised (•) \_\_\_\_\_

U. S. Customary Units Only.

Engine Description / Carb.	5.0 Liter V-8/4-bb1 (305 CID) RPO LG4	5.7 Liter V-8/4-bb1 (350 CID) RPO L48	RPO LB2

**Drive Units — Clutch (Manual Transmission)**

Make & type	Chevrolet, single dry disc semi-centrifugal		
Type pressure plate springs	Circular plate diaphragm, bent finger design		
Total spring load — N (lb.)			
No. of clutch driven discs	One		
Clutch facings	Material	Woven type asbestos	
	Manufacturer	Chevrolet	
	Part Number		
	Rivets/Plate	40	
	Rivet size	.184 x .208	
	Outside & inside dia.	10.34 x 6.50	
	Total eff. area - cm <sup>2</sup> (in. <sup>2</sup> )	101.6	
	Thickness	.140	
Engagement cushion-method	Flat spring steel between friction rings		
Release bearing	Type & method of lubrication	Single row ball, packed and sealed	
Torsional damping	Methods, springs, friction material	Coil springs	

NOT AVAILABLE

**Drive Units — Transmissions**

Manual 3-speed (std., opt U. N.A.)	N.A.	N.A.	N.A.
Manual 4-speed (std., opt., N.A.)	N.A.	Base	N.A.
Manual 5-speed (std., opt., N.A.)	N.A.	N.A.	N.A.
Manual overdrive (std., opt., N.A.)	N.A.	N.A.	N.A.
Automatic (std., opt., N.A.)	Available	Available	Available

**Drive Units — Manual Transmission**

Number of forward speeds	4			
Transmission ratios	In first	2.88		
	In second	1.91		
	In third	1.33		
	In fourth	1.00		
	In fifth	--		
In reverse	2.78			
Synchronous meshing, specify gears	All forward gears			
Shift lever location	Floor mounted in console			
Lubricant	Capacity — L (pt.)	3.4		
	Type recommended	GL-5 gear lubricant		
	SAE viscosity number	Summer	80W or 80W-90	
		Winter	80W or 80W-90	
Extreme cold		80W or 80W-90		

NOT AVAILABLE

**MVMA Specifications Form**  
**Passenger Car**  
**METRIC (U.S. Customary)**

Car Line CORVETTE  
 Model Year 1980 Issued 10/79 Revised (\*) \_\_\_\_\_

U. S. Customary Units Only.

Engine Description / Carb.	5.0 Liter V-8/4-bb1 (305 CID) RPO LG4	5.7 Liter V-8/4-bb1 (350 CID) RPO L48	RPO L82

**Drive Units — Automatic Transmission**

Trade name	3-speed automatic		
Type (describe)	3-speed torque converter		
Selector location	Lever, floor mounted in console		
Gear Ratios	P	Park	
	R	1.93	
	N	Neutral	
	D	2.52 - 1.52 - 1.0	
	L2	2.52 - 1.52	
L1	2.52		
Max upshift speed — drive range — km/h (mph)			
Max kickdown speed — drive range — km/h (mph)			
Torque Converter	Number of elements	3	
	Max. ratio at stall	2.0	
	Type of cooling (air, liquid)	Liquid	
	Nominal diameter	12.2	11.75
Lubricant	Capacity — refill — L (pt.)	8.0	
	Type recommended	Dexron II	
Special transmission features	Converter lock-up final drive		

**Drive Units — Axle**

Type (front, rear)	DANA 44 Rear			
Description	Overhung pinion gear			
Limited Slip differential, type	Standard - disc clutches			
Drive Pinion Offset	1.50			
No. of differential pinions	2			
Pinion adjustment (shim, other)	None			
Pinion bearing ad) (shim, other)	Shim			
Wheel bearing type	Tapered roller			
Lubricant	Capacity — L (pt.)	3.75		
	Type recommended	GL-5 gear lubricant		
	SAE viscosity number	Summer	80W or 80W-90	
		Winter	80W or 80W-90	
Extreme cold		80W or 80W-90		

**Axle Ratio Tooth Combinations** (See "Power Teams" for axle ratio usage.)

Axle Ratio	3.07		
No. of teeth	Pinion	14	
	Ring gear	43	
Ring Gear O. D.	8.50		
Transaxle	Transfer Gear Ratio	--	
	Final Drive Ratio	--	

**MVMA Specifications Form**  
**Passenger Car**  
**METRIC (U.S. Customary)**

Car Line CORVETTE  
 Model Year 1980 Issued 10/79 Revised (\*) 2/80

U. S. Customary Units Only.

Engine Description/Carb.

5.0 Liter V-8/4-bb1 (305 CID) RPO LG4	5.7 Liter V-8/4-bb1 (350 CID)	
	RPO L48	RPO L82

**Drive Units — Propeller Shaft**

Number used		One		
Type (straight tube, tube-in-tube, internal-external damper, etc.)	Right			
	Left			
Outer diam. x length* x wall thick- ness	Manual 3-speed trans.	N.A.	N.A.	N.A.
	Manual 4-speed trans.	N.A.	2.50 x 28.13 x .083	N.A.
	Manual 5-speed trans.	N.A.		
	Overdrive	N.A.		
	Automatic transmission	2.50 x 28.07 x .065		
Inter- mediate bearing	Type (plain, anti-friction)	None		
	Lubrication (fitting prepack)	---		
Slip Yoke	Type	Yoke		
	Number of teeth	Man. trans. - 32; Auto. trans. - 27		
	Spline O.D.	Man. trans. - 1.39; Auto. trans. - 1.17		
Universal joints	Make and Mfg. No.	Man.	#1331 front; #1318 rear	
		Auto.	#1311 front; #1318 rear	
	Number used	Two		
	Type (ball and trunnion, cross)	Cross		
	Rear attach (u-bolt, clamp, etc.)	Strap and bolt		
Bearing	Type (plain, anti-friction)	Anti-friction		
	Lubric. (fitting, prepack)	Prepack		
Drive taken through (torque tube or arms, springs)		Torque control arms		
Torque taken through (torque tube or arms, springs)		Torque control arms		

\* Center to center of universal joints, or to centerline of rear attachment.

**MVMA Specifications Form**  
**Passenger Car**  
**METRIC (U.S. Customary)**

Car Line CORVETTE  
 Model Year 1980 Issued 10/79 Revised (\*) \_\_\_\_\_

U. S. Customary Units Only.

Engine Description/Carb.

5.0 Liter V-8/4-bb1 (305 CID) RPO LG4	5.7 Liter V-8/4-bb1 (350 CID)	
	RPO L48	RPO L82

**Drive Units — Tires And Wheels (Standard)**

TIRES	Size, load range, ply		P225/70R15	
	Type (bias, radial, etc.)		Steel belted radial	
	Inflation pressure (cold) for recommended max. vehicle load	Front-kPa (psi)	35	
		Rear-kPa (psi)	35	
	Rev./mile — at 70 km/h (45 mph)		760	
WHEELS	Type & material		Short spoke spider; steel	
	Rim (size & flange type)		15 x 8	
	Wheel offset		N-0.50	
	Attachment	Type (bolt or stud)	Stud	
		Circle diameter	4.75	
		Number & size	5 hex nuts 7/16-20 UNF2-B	
Spare wheel (same or other)		15 x 5		

**Drive Units — Tires And Wheels (Optional)**

Size, load range, ply		P225/60R15
Type (bias, radial, etc.)		steel belted radial
Wheel type & material		Cast aluminum
Rim (size, flange type, and offset)		15 x 8; N-0.50
Size, load range, ply		
Type (bias, radial, etc.)		
Wheel type & material		
Rim (size, flange type, and offset)		
Size, load range, ply		
Type (bias, radial, etc.)		
Wheel type & material		
Rim (size, flange type, and offset)		
Spare Tire		
Type	Bias ply	
Size	P195/80D15	
Size, load range, ply		
Type (bias, radial, etc.)		
Wheel type & material		
Rim (size, flange type, and offset)		

**Brakes — Parking**

Type of control		Grip handle control
Location of control		Between seats
Operates on		Rear brake drums inboard of disc rotors on axle shafts
If separate from service brakes	Type (internal or external)	Internal
	Drum diameter	6.50
	Lining size (length x width x thickness)	6.78 x 1.25 x 0.175

**MVMA Specifications Form**  
**Passenger Car**  
**METRIC (U.S. Customary)**

Car Line CORVETTE  
 Model Year 1980 Issued 10/79 Revised (•) \_\_\_\_\_  
U. S. Customary Units Only.  
 Body Type And/Or Engine Displacement

2-Door Sport Coupe

**Brakes — Service**

<b>Brake Type</b> (std., Opt., N.A.)	Drum	Front		---
		Rear		---
	Disc	Front		Std.
		Rear		Std.
Self-adjusting (std., opt., N.A.)				Std.
<b>Special Valving</b>	Type (proportion, delay, metering, other)			Proportioning
Power Brake (std., opt., N.A.)				Std.
Booster Type (remote, integral, vac., hyd., etc.)				Integral
Anti-skid device type (std., opt., N.A.)				N.A.
Effective area — cm <sup>2</sup> (in. <sup>2</sup> )*				74.92
Gross lining area — cm <sup>2</sup> (in. <sup>2</sup> )**				86.30
Swept area — cm <sup>2</sup> (in. <sup>2</sup> )* **				498.30
<b>Rotor</b>	Outer working diameter	F		11.75
		R		11.75
	Thickness	F		1.25
		R		1.25
	Material & type (vented/solid)	F		Cast iron, vented
		R		Cast iron, vented
<b>Drum</b>	Diameter (nominal)			---
	Type and material			---
<b>Wheel cyl. inner bore</b>	Front			1.875
	Rear			1.375
<b>Master Cylinder</b>	Bore			1.125
	Stroke			1.14
Pedal arc ratio				3.5:1
Line pressure at 445 N (100 lb.) pedal load — MPa (psi)				
<b>Lining Clearance Per Shoe</b>	Front			Self adjusting
	Rear			Self adjusting
<b>Brake Lining</b>	<b>Front Wheel</b>	Bonded or riveted, rivets/seg.		Riveted, 8
		Rivet size		.143 x .250
		Manufacturer		Delco Moraine
		Lining Code		GM 106 FE
		Material		Molded asbestos
		---- Prim. or out-board		5.40 x 1.93 x .41
	Size Second or in-board		5.40 x 1.93 x .41	
	Shoe thickness (no lining)		.500	
	<b>Rear Wheel</b>	Bonded or riveted, rivets/seg.		Riveted, 8
		Manufacturer		Delco Moraine
		Lining Code		GM 106 FE
		Material		Molded asbestos
---- Prim. or out-board			5.40 x 1.93 x .41	
Size Second or in-board			5.40 x 1.93 x .41	
Shoe thickness (no lining)		.500		

\*Excludes rivet holes, grooves, chamfers, etc.

\*\*Includes rivet holes, grooves, chamfers, etc.

\*\*\*Total swept area for four brakes. (Drum brake: Widest lining contact width for each brake x its contact circumference.) (Disc brake Square of Outer Working Dia. minus Square of Inner Working Dia. multiplied by z/2 for each brake.)

\*\*\*\*Size for drum brakes includes length x width x thickness.

**MVMA Specifications Form**  
**Passenger Car**  
**METRIC (U.S. Customary)**

Car Line CORVETTE  
 Model Year 1980 Issued 10/79 Revised (\*) 2/80  
U. S. Customary Units Only.

2-Door Sport Coupe

**Steering**

Manual (std., opt., N.A.)		N.A.	
Power (std., opt., N.A.)		Std.	
Adjustable steering wheel (fill, swing, other)	Type and description	Tilt and telescopic steering wheel; 2" adjustment	
	(Std., opt., N.A.)	Standard	
Wheel diameter	Manual	---	
	Power	14.5	
Turning diameter m (feet)	Outside front	Wall to wall (l. & r.)	41.3
		Curb to curb (l. to r.)	40.4
	Inside rear	Wall to wall (l. to r.)	
		Curb to curb (l. to r.)	
Manual	Gear	Type	Not available
		Make	
		Ratios	
		Gear Overall	
	No wheel turns (stop to stop)		
Power	Type (coaxial, linkage, etc.)		Linkage, power pump, assisted
	Make		Saginaw Steering Gear
	Gear	Type	Semi-reversible, recirculating ball nut
		Ratios	16.1:1
		Gear Overall	17.6:1
	Pump driven by		Crankshaft pulley
No wheel turns (stop to stop)			2.58
Linkage	Type		Parallel-o-gram
	Location (front or rear of wheels, other)		Rear
	Drag links (trans. or longtr.)		None
	Tie rods (one or two)		Two
Steering Axis	Inclination at camber (deg.)		
	Bearings (type)	Upper	Ball stud with non-metallic bearing surface
		Lower	Ball stud with non-metallic bearing surface
		Thrust	
Steering spindle & joint type			Steering knuckle with spherical joint
Wheel Spindle	Diameter	Inner bearing	1.3743-1.3748
		Outer bearing	0.8428-0.8433
	Thread size		27/32-20 UNEF modified
	Bearing type		Tapered roller
Wheel Align at curb mass (wt.)	Service checking	Caster (deg.)	+1-1/4 to +3-1/4
		Camber (deg.)	0 to +1-1/2
		Toe-in (outside track-mm (in.))	+0.12 to +0.36
	Service reset	Caster	+2-1/4 ± 1/4
		Camber	3/4 ± 1/2
		Toe-in	+0.25 ± 0.06
	Periodic M.V. Inspection	Caster	+1/4 to +4-1/4
		Camber	-3/4 to +2-1/4
		Toe-in	-0.12 to +0.60

Rear Wheel Alignment: -Camber, 0° ± 0°30' toe in .06° ± .06°

**MVMA Specifications Form**  
**Passenger Car**  
**METRIC (U.S. Customary)**

Car Line CORVETTE  
 Model Year 1980 Issued 10/79 Revised (\*) \_\_\_\_\_

U. S. Customary Units Only.

Body Type And/Or Engine Displacement

2-Door Sport Coupe

**Suspension — General**

(See Supplement page for details on Air Suspension)

Provision for car leveling	Front stabilizer shaft
Provision for brake dip control	Mounting angle at front upper control arm
Provision for acc. squat control	None
Special provisions for car jacking	Front-5" forward of front door opening, under frame Rear-3" forward of wheel opening, under frame
Shock absorber front & rear	Direct, double acting hydraulic
Type	Delco
Make	
Piston dia.	1.0 (a)
Other special features	

**Suspension — Front**

Type and description	Independent, SLA with coil springs	
Travel	Full Jounce	4.76
	Full Rebound	2.94
Spring	Type (coil, leaf, other)	Coil
	Material	Steel alloy
	Size (coil design height & I.D., bar length x dia.) (a)	10.45 x 3.80; 138.86 x .620
	Spring rate — N/mm (lb./in.) (a)	260
	Rate at wheel — N/mm (lb./in.) (a)	97
Stabilizer	Type (link, linkless, frameless)	Link
	Material & bar diameter	HR steel - 1.12

**Suspension — Rear**

Type and description	Fully independent with fixed differential, transverse multi-leaf spring, lateral struts & 'U' jointed axle shafts	
Drive and torque taken through	Torque control arms	
Travel	Full Jounce	4.00
	Full Rebound	3.00
Spring	Type (coil, leaf, other)	Leaf
	Material	Chrome carbon steel
	Size (length x width, coil design height & I.D., bar length & dia.) (a)	48.6 x 2.5
	Spring rate — N/mm (lb./in.) (a)	172
	Rate at wheel — N/mm (lb./in.) (a)	121
	Mounting insulation type	Rubber mounted at differential, vertical loading only at shackles
II leaf	No. of leaves	8
	Shackle (comp. or tens.)	Tension
Stabilizer	Type (link, linkless, frameless)	Link (RPD FE7 gymkhana suspension only)
	Material & bar diameter	HR steel - 0.440
Track bar type	None	

(a) For base equipped model, springs are computer selected by size and rate according to vehicle weight including optional equipment. Spring rates and shock absorber equipment may vary when engine, transmission or Gymkhana suspension options are used.



**IVMA Specifications Form**  
**Passenger Car**  
**METRIC (U.S. Customary)**

Car Line CORVETTE  
 Model Year 1980 Issued 10/79 Revised (\*) 2/80

**Body Type**

2-Door Sport Coupe

**Body — Miscellaneous Information**

Type of finish (lacquer, enamel, other)		Lacquer
Hood Hinge Location		Front
Hood counterbalance (type)		Hood is not counterbalanced, hood is held open with link
Hood release control (internal, external)		Internal
Vehicle Ident. No. Location		Left hand windshield pillar
Vent window control method (crank, friction pivot, power)		None
		None
Seat cushion type	Front	Bucket, Polyurethane padding
	Rear	None
	3rd Seat	None
Seat back type	Front	Bucket, Polyurethane padding
	Rear	None
	3rd Seat	None
Method of holding luggage compartment lid open		--
Position of spare tire storage		In well under body at rear.

**Frame**

Type and description (Separate frame, unitized frame, partially-unitized frame)	Crossmember for trans. support and rear axle bolted in. All welded, full length, ladder constructed, frame with (3) welded in crossmembers.
---	---

**MVMA Specifications Forms**  
**Passenger Car**  
**METRIC (U.S. Customary)**

Car Line CORVETTE  
 Model Year 1980 Issued 10/79 Revised (\*) \_\_\_\_\_

Body Type

2-Door Sport Coupe

**Convenience Equipment**

Power windows	Side Windows	Standard
	Vent Windows	NA
	Backlight or tailgate	NA
Power seats (specify type as well as availability)		NA
Reclining front seat back (R-L or both)		NA
Radios (specify type as well as availability)		AM/FM standard. Optional - AM/FM stereophonic, AM/FM stereo-CB, AM/FM stereo with 8 track tape, AM/FM stereo with cassette tape
Rear seat speaker		Optional - dual rear auxiliary speakers
Power antenna		Optional Triband included with CB unit
Clock		Standard
Air Conditioner (specify type)		Standard - four season, manual control
Speed warning device		NA
Speed control device		Optional - automatic transmission models only
Ignition lock lamp		NA
Dome lamp		Standard (delay feature standard)
Glove compartment lamp		Standard
Luggage compartment lamp		N.A. (illuminated by dome lamp)
Underhood lamp		Standard
Courtesy lamp		Standard (delay feature standard)
Map lamp		NA
Cornering lamp		Standard
Rear window defroster electrically heated		Optional
Rear window defogger		NA
Theft protection - type		- Lock mounted on steering column; locks steering wheel, and ignition, anti-theft alarm under hood signals tampering with doors, hood and lift out roof panels, drivers door key lock arms or disarms alarm system



**MVMA Specifications Form**  
**Passenger Car**  
**METRIC (U.S. Customary)**

Car Line CORVETTE  
 Model Year 1980 Issued 10/79 Revised (\*) \_\_\_\_\_

Equipment Differential Mass (Weights)	Optional Equipment Mass (Weight)*			Remarks
	MASS kg (Weight, lb.)			
	Front	Rear	Total	
Glass Roof Panels	2.2	4.0	6.2	
	(+4.8)	(+8.8)	(+13.5)	
Control-Speed & Cruise	2.4	0	2.4	
	(+5.3)	( 0 )	(+5.3)	
Heavy Duty Battery	0	2.2	2.2	
	( 0 )	(+4.8)	(+4.8)	
Radio AM/FM Stereophonic	2.7	1.8	4.5	
	(+6.0)	(+4.0)	(+10.0)	
Radio AM/FM Stereophonic with 8 Track Tape Player	3.2	2.7	5.9	
	(+7.0)	(+6.0)	(+13.0)	
Radio AM/FM Stereophonic with Cassette Tape Player	3.2	2.3	5.5	
	(+7.0)	(+5.0)	(+12.0)	
Radio AM/FM Stereophonic with Citizen's Band	2.7	1.8	4.5	
	(+6.0)	(+4.0)	(+10.0)	
Dual Auxiliary Rear Speakers	0	1.2	1.2	NA with standard AM/FM push-button radio
	( 0 )	(+2.6)	(+2.6)	
Power Antenna	0	1.0	1.0	All radios except citizen's band
	( 0 )	(+2.2)	(+2.2)	
Power Antenna - Tri Band	0	1.0	1.0	
	( 0 )	(+2.2)	(+2.2)	
Gymkhana Susp. Front&Rear	2.4	0	2.4	
	(+5.3)	( 0 )	(+5.3)	
Carrier-Roof Panel	0	7.2	7.2	
	( 0 )	(+15.9)	(+15.9)	
Wheels Cast Aluminum	-8.8	-8.8	-17.6	
	(-19.4)	(-19.4)	(-38.8)	
305 CID V8 Engine RPO 1G4	-0.4	0	-0.4	California only
	(-0.9)	( 0 )	(-0.9)	
350 CID V8 Engine RPO 1B2	7.0	2.0	9.0	
	(+15.4)	(+4.4)	(+19.8)	
3-Speed Automatic Trans.	6.4	3.8	10.2	Used with 305 CID V8 Engine RPO 1G4
	(+14.1)	(+8.4)	(+22.5)	
	6.8	4.4	11.2	Used with 350 CID V8 Engine RPO 1B2
	(+15.0)	(+9.7)	(+24.7)	
	6.6	4.2	10.8	Used with 350 CID V8 Engine RPO 1B2
	(+14.5)	(+9.3)	(+23.8)	

\*Also see Engine — General Section for dressed engine mass (weight)

**MVMA Specifications Form**  
**Passenger Car**  
**METRIC (U.S. Customary)**  
**Car and Body Dimensions** See Key Sheets for definitions

Car Line CORVETTE  
 Model Year 1980 Issued 10/79 Revised (\*) 2/80

All dimensions to ground are for comparative purposes only. Dimensions are to be shown for all base body models of each car line.  
 SAE Ref. No. refers to the definition published in SAE Recommended Practice.  
 J1100a "Motor Vehicle Dimensions," unless otherwise specified.

**Body Type**

SAE Ref. No.	2-Door Sport Coupe
--------------	--------------------

**Width**

Tread - Front	W101	1491 (58.7)
Tread - Rear	W102	1511 (59.5)
Vehicle width	W103	1753 (69.0)
Body width at Sg RP - front	W117	1638 (64.5)
Vehicle width - front doors open	W120	3467 (136.5)
Vehicle width - rear doors open	W121	---

**Length**

Wheelbase	L101	2489 (98.0)
Vehicle length	L103	4707 (185.3)
Overhang - front	L104	1077 (42.4)
Overhang - rear	L105	1140 (44.9)
Upper structure length	L123	2090 (82.3)
Rear wheel C/L "X" coordinate	L127	1829 (72.0)
Cowl point "X" coordinate	L125	409 (16.1)

**Height\***

Passenger Distribution (fr./rear)	PD1.2.3	2-0
Trunk/Cargo load		0
Vehicle height	H101	1222 (48.1)
Cowl point to ground	H114	899 (35.4)
Deck point to ground	H136	
Rocker panel front to ground	H112	206 (8.1)
Bottom of door closed - front to grd.	H133	254 (10.0)
Rocker panel rear to ground	H111	195 (7.7)
Bottom of door closed - rear to grd.	H135	---

**Ground Clearance\***

Front bumper to ground	H102	239 (9.4)
Rear bumper to ground	H104	289 (11.4)
Bumper to ground - front at curb mass (wt.)	H103	246 (9.7)
Bumper to ground - rear at curb mass (wt.)	H105	317 (12.5)
Angle of approach	H106	13.91°
Angle of departure	H107	16.55°
Ramp breakover angle	H147	12.49°
Rear axle differential to ground	H153	145 (5.7)
Min. running ground clearance	H156	104 (4.1) (a)
Location of min. run. grd. clear.		(a) Catalytic converter

All linear dimensions are in millimeters (inches) and all mass (weight) specifications are in kilograms (pounds)

\* All vehicle height and ground clearances are made at the Manufacturer's Design Load Weight, unless otherwise specified. Manufacturer's Design Load Weight is defined with indicated passenger distribution and trunk/cargo load.

# MVMA Specifications Form

Passenger Car  
METRIC (U.S. Customary)

Car and Body Dimensions See Key Sheets for definitions

Car Line CORVETTE  
Model Year 1980 Issued 10/79 Revised (\*) \_\_\_\_\_

### Body Type

SAE Ref. No.	2-Door Sport Coupe
--------------------	--------------------

### Front Compartment

Sg RP front, "X" coordinate	L31	1135 (44.7)
Effective head room	H61	919 (36.2)
Effective T Point head room	H75	935 (36.8)
Max. eff. leg room — accelerator	L34	1069 (42.1)
Sg RP — front to heel	H30	162 (6.4)
Design H-point front travel	L17	137 (5.4)
Shoulder room	W3	1206 (47.5)
Hip room	W5	1267 (49.9)
Upper body opening to ground	H50	1130 (44.5)
Steering Wheel Angle	H18	15.0°
Back Angle	L40	33°

### Rear Compartment

Sg RP Point couple distance	L50	
Effective head room	H63	
Effective T Point head room	H76	
Min. effective leg room	L51	
Sg RP — second to heel	H31	
Knee clearance	L48	NOT
Compartment room	L3	APPLICABLE
Shoulder room	W4	
Hip room	W6	
Upper body opening to ground	H51	

### Luggage Compartment

Usable luggage capacity — L (cu. ft.)	V1	238L (8.4)
Liftover height	H195	---

All linear dimensions are in millimeters (inches).

# MVMA Specifications Form

Passenger Car

METRIC (U.S. Customary)

Car and Body Dimensions See Key Sheets for definitions

Car Line CORVETTE  
 Model Year 1980 Issued 10/79 Revised (•) \_\_\_\_\_

**Body Type**

SAE Ref. No.	2-Door Sport Coupe
--------------	--------------------

**Station Wagon — Third Seat**

Shoulder room	W85	
Hip room	W86	
Effective leg room	L86	
Effective head room	H86	NOT APPLICABLE
Effective T Point head room	H89	
Seat facing direction	SD1	

**Station Wagon — Cargo Space**

Cargo length — open — front	L200	
Cargo length — open — second	L201	
Cargo length — closed — front	L202	
Cargo length — closed — second	L203	
Cargo length at belt — front	L204	
Cargo length at belt — second	L205	NOT APPLICABLE
Cargo width — wheelhouse	W201	
Rear opening width at floor	W203	
Opening width at belt	W204	
Max. rear opening width above belt	W205	
Cargo height	H201	
Rear opening height	H202	
Tail gate to ground height	H250	
Front seat back to load floor height	H197	
Cargo volume index — m <sup>3</sup> (ft. <sup>3</sup> )	V2	
Hidden cargo volume — m <sup>3</sup> (ft. <sup>3</sup> )	V4	

**Hatchback — Cargo Space**

Front seat back to load floor height	H197	
Cargo length at front seat		
Back Height	L208	NOT APPLICABLE
Cargo length at floor — front	L209	
Cargo volume index — m <sup>3</sup> (ft. <sup>3</sup> )	V3	
Hidden cargo volume — m <sup>3</sup> (ft. <sup>3</sup> )	V4	

A printed or computer tape supplement containing additional car and body dimensions and/or drawings (based in part on SAE J1100a "Motor Vehicle Dimensions") may be available from the manufacturer.

All dimensions are in millimeters (inches).

**MVMA Specifications Form**  
**Passenger Car**  
**METRIC (U.S. Customary)**  
**Car and Body Dimensions** See Key Sheets for definitions

Car Line CORVETTE  
 Model Year 1980 Issued 10/79 Revised (\*) \_\_\_\_\_

Body Type

2-Door Sport Coupe

**Vehicle Fiducial Marks**

Fiducial Mark Number *	Define Coordinate Location															
Front	<p>X - Fiducial mark to vertical base grid line-front, measured horizontally from the base grid line to the front fiducial mark located on top of the front seat adjuster mounting bolt.</p> <p>Y - Fiducial mark to centerline of car-front, width measurement made from centerline of car to fiducial mark located on top of the front seat adjuster mounting bolt.</p> <p>Z - Fiducial mark to horizontal base grid line-front, measured vertically from base grid line to front fiducial mark located on top of the front seat adjuster mounting bolt.</p>															
Rear	<p>X - Fiducial mark to vertical base grid line-rear measured horizontally from base grid line to the rear fiducial mark located on rear underbody crossbar.</p> <p>Y - Fiducial mark to centerline of car-rear, width measurement made from centerline of car to fiducial mark located on the rear underbody crossbar.</p> <p>Z - Fiducial mark to horizontal base grid line-rear, measured vertically from base grid line to the rear fiducial mark located on rear underbody crossbar.</p>															
Fiducial Mark Number																
Front	<table style="width: 100%; border-collapse: collapse;"> <tr><td style="width: 10%;">W21</td><td style="width: 40%;">686</td><td style="width: 50%;">(27.02)</td></tr> <tr><td>L54</td><td>786</td><td>(30.95)</td></tr> <tr><td>H81</td><td>54</td><td>(2.13)</td></tr> <tr><td>M181</td><td>266</td><td>(10.49)</td></tr> <tr><td>H183</td><td>247</td><td>(9.74)</td></tr> </table>	W21	686	(27.02)	L54	786	(30.95)	H81	54	(2.13)	M181	266	(10.49)	H183	247	(9.74)
W21	686	(27.02)														
L54	786	(30.95)														
H81	54	(2.13)														
M181	266	(10.49)														
H183	247	(9.74)														
Rear	<table style="width: 100%; border-collapse: collapse;"> <tr><td style="width: 10%;">W22</td><td style="width: 40%;">513</td><td style="width: 50%;">(24.14)</td></tr> <tr><td>L55</td><td>2240</td><td>(88.18)</td></tr> <tr><td>H82</td><td>320</td><td>(12.62)</td></tr> <tr><td>M182</td><td>529</td><td>(20.84)</td></tr> <tr><td>H184</td><td>502</td><td>(19.78)</td></tr> </table>	W22	513	(24.14)	L55	2240	(88.18)	H82	320	(12.62)	M182	529	(20.84)	H184	502	(19.78)
W22	513	(24.14)														
L55	2240	(88.18)														
H82	320	(12.62)														
M182	529	(20.84)														
H184	502	(19.78)														

\*Reference — SAE Recommended Practice, J182a, A Motor Vehicle Fiducial Marks — September, 1973.  
 All linear dimensions are in millimeters (Inches).



**MVMA Specifications Form**  
**Passenger Car**  
**METRIC (U.S. Customary)**  
**Car and Body Dimensions** See Key Sheets for definitions

Car Line CORVETTE  
 Model Year 1980 Issued 10/79 Revised (\*) 2/80

**Body Type**

SAE Ref. No.	2-Door Sport Coupe
--------------	--------------------

**Glass**

● Backlight slope angle	H121	70.0°
Windshield slope angle	H122	57.0°
Tumble-Home	W122	7.4
Windshield glass exposed surface area — cm <sup>2</sup> (in. <sup>2</sup> )	S1	5119 (793.5)
Side glass exposed surface area — cm <sup>2</sup> (in. <sup>2</sup> )	S2	5166 (800.8)
Backlight glass exposed surface area — cm <sup>2</sup> (in. <sup>2</sup> )	S3	9195 (1425.3)
Total glass exposed surface area — cm <sup>2</sup> (in. <sup>2</sup> )	S4	19480 (3019.6)
Windshield glass type		Curved - Laminated Plate - Tinted
Side glass type		Curved - Tempered Plate - Tinted
Backlight glass type		Curved - Tempered Plate - Tinted

**Lamps and Headlamp Shape \***

Height above ground to center of bulb or marker	Headlamp (H127)	Highest **	663 (26.1)
		Lowest	660 (26.0)
	Tail (H128)	Highest	635 (25.0)
		Lowest	635 (25.0)
	Sidemarker	Front	442 (17.4)
		Rear	480 (18.9)
Distance from C/L of car to center of bulb	Headlamp	Inside	
		Outside **	
	Tail	Inside	
		Outside	
	Directional	Front	
		Rear	
Headlamp Shape		Round	

\*Measured at curb mass (weight).  
 \*\* If single headlamps are used enter here



**MVMA Specifications Form**  
**Passenger Car**  
**METRIC (U.S. Customary)**

**Interior Car And Body Dimensions — Key Sheet**

**Front Compartment**

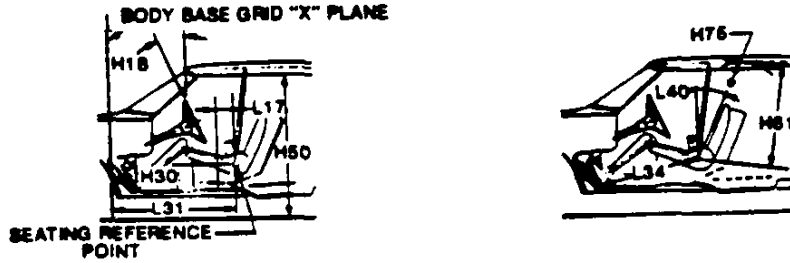

**Rear Compartment**

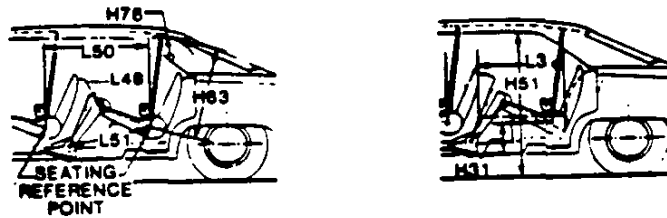

**Third Seat**

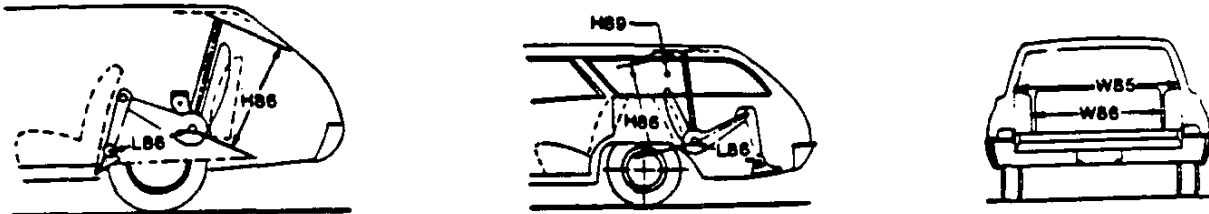

**Interior Width**

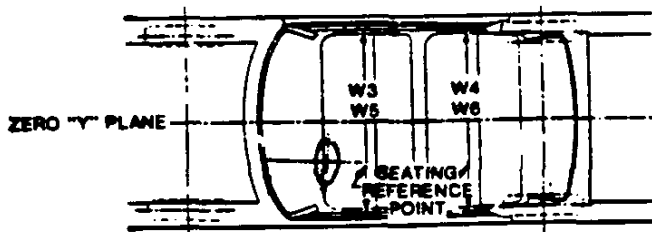

# MVMA Specifications Form

## Passenger Car

### METRIC (U.S. Customary)

#### Exterior Car And Body Dimensions — Key Sheet

#### Dimensions Definitions

<b>Seating Reference Point</b>		L123	UPPER STRUCTURE LENGTH. The dimension measured longitudinally from the cowl point to the deck point.
SEATING REFERENCE POINT means the manufacturer's design reference point which —		L127	REAR WHEEL CENTERLINE "X" COORDINATE or in the case of dual rear axles, the coordinate shall be in the midpoint of the distance between the rear axle centerlines.
(a) Establishes the rearmost normal design driving or riding position of each designated seating position in a vehicle;		L125	COWL POINT "X" COORDINATE.
(b) Has coordinates established relative to the design vehicle structure;		<b>Height Dimensions</b>	
(c) Simulates the position of the pivot center of the human torso and thigh; and		H101	VEHICLE HEIGHT. The dimension measured vertically from the highest point on the vehicle body to ground.
(d) Is the reference point employed to position the two dimensional templates described in SAE Recommended Practice J826, "Manikins for Use in Defining Vehicle Seating Accommodations," November 1962.		H114	COWL POINT TO GROUND. Measured at zero "Y" plane.
<b>Width Dimensions</b>		H138	DECK POINT TO GROUND. Measured at zero "Y" plane.
W101	TREAD — FRONT. The dimension measured between the tire centerlines at the ground.	H112	ROCKER PANEL — FRONT TO GROUND. The dimension measured vertically from the foremost point on the bottom of the rocker panels, excluding flanges, to ground.
W102	TREAD — REAR. The dimension measured between the tire centerlines at the ground. In case of dual wheels, the dimension will be measured to the centerline of tire and wheel assemblies.	H132	BOTTOM OF DOOR OPEN — FRONT TO GROUND. The dimension measured vertically from the bottom outside corner of the door on the lock pillar side, in maximum hold-open position, to ground.
W103	VEHICLE WIDTH. The maximum dimension measured between the widest point on the vehicle, excluding exterior mirrors, flexible mud flaps, marker lamps, but including bumpers, moldings, sheet metal protrusions or dual wheels, if standard equipment.	H111	ROCKER PANEL — REAR TO GROUND. The dimension measured vertically from the bottom of the rocker or side quarter panel at the front of the rear wheel opening, excluding flanges, to ground.
W117	BODY WIDTH AT SgRP — FRONT. The dimension measured laterally between the widest points on the body at the SgRP - front, excluding door handles, applied moldings or appliques.	H134	BOTTOM OF DOOR OPEN — REAR TO GROUND. The dimension measured vertically from the bottom outside corner of the door on the lock pillar side, in maximum hold-open position, to ground.
W120	VEHICLE WIDTH — FRONT DOORS OPEN. The dimension measured between the widest point on the front doors in maximum hold-open position.	H135	BOTTOM OF DOOR CLOSED — REAR TO GROUND. The dimension measured vertically from the bottom outside corner of the door on the lock pillar side, in maximum closed position, to ground.
W121	VEHICLE WIDTH — REAR DOORS OPEN. The dimension measured between the widest point on the rear doors in maximum hold-open position. For vehicles with a rear door on only one side, this dimension is to the zero "Y" plane.	H121	BACKLIGHT SLOPE ANGLE. The angle between the vertical reference line and the surface of backlight at vehicle zero "Y" plane. For curve backlight, the angle is to chord of backlight arc from lower DLO to upper DLO.
W122	TUMBLE HOME. STRAIGHT SIDE GLASS. The angle measured from a vertical to the outside surface of the front door glass at the SgRP "X" plane. CURVED SIDE GLASS. The angle measured from a vertical to a chord extending from the upper DLO to the lower DLO at the outside surface of the front door glass at the front SgRP "X" plane.	H122	WINDSHIELD SLOPE ANGLE. The angle between the vertical reference line and a chord of the windshield are running from the lower DLO to the upper DLO at the vehicle zero "Y" plane. In the case of wrap over glass, the angle to be measured will be formed by a chord 18.0 in. (457 mm) long, drawn from the lower DLO to the intersecting point on the windshield.
<b>Length Dimensions</b>		H127	HEADLAMP TO GROUND — CURB WEIGHT. The dimension measured vertically from the centerline of the lowest headlamp lens to ground.
L30	FRONT OF DASH "X" COORDINATE. A minus (-) dimension indicates actual front of dash is forward of the zero "X" plane.	H128	TAILLAMP TO GROUND — CURB WEIGHT. The dimension measured vertically from the centerline of the upper bulb to ground.
L101	WHEELBASE (WB). The dimension measured longitudinally between front and rear wheel centerlines. In case of dual rear axles, the dimension shall be to the midpoint of the centerlines of the rear wheels.	<b>Ground Clearance Dimensions</b>	
L102	TIRE SIZE. As specified by the manufacturer.	H102	FRONT BUMPER TO GROUND. The minimum dimension measured vertically from the lowest point on the front bumper to ground, including bumper guards, if standard equipment.
L103	VEHICLE LENGTH. The maximum dimension measured longitudinally between the foremost point and the rearmost point on the vehicle, including bumper, bumper guards, two hooks and/or rub strips, if standard equipment.	H103	FRONT BUMPER TO GROUND — CURB WEIGHT. Measured in the same manner as H104.
L104	OVERHAND — FRONT. The dimension measured longitudinally from the centerline of the front wheels to the foremost point on the vehicle including bumper, bumper guards, two hooks and/or rub strips, if standard equipment.	H104	REAR BUMPER TO GROUND. The minimum dimension measured vertically from the lowest point on the rear bumper to ground, including bumper guards, if standard equipment.
L105	OVERHAND — REAR. The dimension measured longitudinally from the centerline of the rear wheels; or in the case of dual rear axles, the dimension shall be the midpoint of the centerlines of the rear wheels, to the rearmost point on the vehicle, including rear bumpers, bumper guards, two hooks and rub strips, if standard equipment.	H105	REAR BUMPER TO GROUND — CURB WEIGHT. Measured in the same manner as H104.
		H106	ANGLE OF APPROACH. The angle measured between a line tangent to the front tire static loaded radius are the initial point of structural interference forward of the front tire to ground. The limiting structural component shall be designated.

# MVMA Specifications Form

## Passenger Car

### METRIC (U.S. Customary)

#### Interior Car And Body Dimensions — Key Sheet

#### Dimensions Definitions

H107	ANGLE OF DEPARTURE. The angle measured between a line tangent to the rear tire static loaded radius and the initial point of structural interference rearward of the rear tire to ground. The limiting component shall be designated.	L51	MINIMUM EFFECTIVE LEG ROOM — SECOND. The dimension measured along a line from the ankle pivot center to the SgRP — second plus 10.0 in. (254 mm).
H147	REAR BREAKOVER ANGLE. The angle measured between two lines tangent to the front and rear tire static loaded radius and intersecting at a point on the underside of the vehicle which defines the largest ramp over which the vehicle can roll.	H31	SgRP — SECOND TO HEEL. The dimension measured vertically from the SgRP — second to the two dimensional device heel point on the depressed floor covering.
H153	REAR AXLE DIFFERENTIAL TO GROUND. The minimum dimension measured from the rear axle differential to ground.	L48	KNEE CLEARANCE — SECOND. The minimum dimension measured from the knee pivot to the back of front seatback minus 2.0 in. (51 mm).
H156	MINIMUM RUNNING GROUND CLEARANCE. The minimum dimension measured from the sprung vehicle to ground. Specify location.	L3	COMPARTMENT ROOM — SECOND. The dimension measured horizontally from the back of front seat to the front of the second seatback at a height tangent to the top of the second seat cushion.
<b>Front Compartment Dimensions</b>			
PD1	PASSENGER DISTRIBUTION — FRONT.	W4	SHOULDER ROOM — SECOND. The minimum dimension measured laterally between trimmed surfaces on the "X" plane through the SgRP — second within 10.0-16.0 in. (254-406 mm) above the SgRP — second.
L31	SgRP — FRONT "X" COORDINATED.	W6	HIP ROOM — SECOND. Measured in the same manner as W5.
H61	EFFECTIVE HEAD ROOM — FRONT. The dimension measured along a line 8 deg. rear of vertical from the SgRP — front to the headline, plus 4.0 in. (102 mm).	H51	UPPER BODY OPENING TO GROUND — SECOND. The dimension measured vertically from the trimmed body opening to the ground on the "X" plane 13.0 in. (330 mm) forward of the SgRP — second.
H75	EFFECTIVE T-POINT HEAD ROOM — FRONT. The minimum radius from the T-point to the headlining plus 30 in. (762 mm).	<b>Luggage Compartment Dimensions</b>	
L34	MAXIMUM EFFECTIVE LEG ROOM — ACCELERATOR. The dimension measured along a line from the ankle pivot center to the SgRP — front plus 10.0 in. (254 mm) measured with right foot on the undepressed accelerator pedal. For vehicles with SgRP to heel (H30) greater than 18 in., the accelerator pedal may be depressed as specified by the manufacturer. If the accelerator is depressed, the manufacturer shall place foot flat on pedal and note the depression of the pedal.	V1	USABLE LUGGAGE CAPACITY — Total of volumes of individual pieces of standard luggage set plus H-boxes stowed in the luggage compartment in accordance with the procedure described in paragraph 6.2 of SAE J1100a.
H30	SgRP — FRONT TO HEEL. The dimension measured vertically from the SgRP — front to the accelerator heel point.	H195	LIFTOVER HEIGHT. The dimension measured vertically from the luggage compartment lower opening at the zero "Y" plane to ground
L17	DESIGN H-POINT — FRONT TRAVEL. The dimension measured horizontally between the design H-point — front in the foremost and rearmost seat trace positions.	<b>Station Wagon — Third Seat Dimensions</b>	
W3	SHOULDER ROOM — FRONT. The minimum dimension measured laterally between the trimmed surfaces on the "X" plane through the SgRP — front within the belt line and 10.0 in. (254 mm) above the SgRP — front.	PD3	PASSENGER DIRECTION — TH : J
W5	HIP ROOM — FRONT. The minimum dimension measured laterally between the trimmed surfaces on the "X" plane through the SgRP — front within 1.0 in. (25 mm) below and 3.0 (76 mm) above the SgRP — front and 3.0 (76 mm) fore and aft of the SgRP — front.	W85	SHOULDER ROOM — THIRD. Measured in the same manner as W5.
H150	UPPER BODY OPENING TO GROUND — FRONT. The dimension measured vertically from the trimmed body opening to the ground on the SgRP — front "X" plane.	W86	HIP ROOM — THIRD. Measured in the same manner as W5.
H18	STEERING WHEEL ANGLE. The angle measured from a vertical to the surface plane of the steering wheel.	L86	EFFECTIVE LEG ROOM — THIRD. The dimension measured along a line from the ankle pivot center to the SgRP — third plus 10.0 in. (254 mm).
L40	BACK ANGLE — FRONT. The angle measured between a vertical line through the SgRP — front and the torso line. If the seatback is adjustable, use the normal driving and riding position specified by the manufacturer.	H86	EFFECTIVE HEAD ROOM — THIRD. The dimension, measured along a line 8 deg. from the SgRP — third to the headlining rear of vertical plus a constant of 4.0 in. (102 mm).
<b>Rear Compartment Dimensions</b>			
PD2	PASSENGER DISTRIBUTION — SECOND.	H89	EFFECTIVE T-POINT HEAD ROOM — THIRD. Measured in the same manner as H75.
L50	SgRP COUPLE DISTANCE. The dimension measured horizontally from the driver SgRP — front to the SgRP — second.	<b>Station Wagon — Cargo Space Dimensions</b>	
H63	EFFECTIVE HEAD ROOM — SECOND. The dimension measured along a line 8 deg. rear of vertical from the SgRP to the headlining, plus 4.0 in. (102 mm).	L200	CARGO LENGTH — OPEN — FRONT. The minimum dimension measured longitudinally from the back of the front seatback at the height of the undepressed floor covering to the rearmost point on the undepressed floor covering on the open tailgate or cargo surface if the rear closure is a conventional door type tailgate, at the zero "Y" plane.
H76	EFFECTIVE T-POINT HEAD ROOM — SECOND. Measured in the same manner as H75.	L201	CARGO LENGTH — OPEN — SECOND. The dimension measured longitudinally from the back of the second seatback at the height of the undepressed floor covering on the open tailgate or cargo floor surface if the rear closure is a conventional door type tailgate, at the zero "Y" plane.
<b>L202</b>			
CARGO LENGTH — CLOSED — FRONT. The minimum dimension measured horizontally from the back of the front seat at the height of the undepressed floor covering to the rearmost point on the undepressed floor covering on the closed tailgate or taildoor for station wagons, trucks and mpv's at the zero "Y" plane.			

**MVMA Specifications Form**  
**Passenger Car**  
**METRIC (U.S. Customary)**

**Interior Car And Body Dimensions — Key Sheet**  
**Dimensions Definitions**

- L203 CARGO LENGTH — CLOSED — SECOND.** The dimension measured horizontally from the back of the second seat at the height of the undepressed floor covering to the rearmost point on the undepressed floor covering on the closed tailgate or taildoor for station wagons, trucks and mpv's at the zero "Y" plane.
- L204 CARGO LENGTH AT BELT — FRONT.** The minimum dimension measured horizontally from the back of the front seatback at the seatback top to the foremost normal surface of the closed tailgate or inside surface of the cab back panel at the height of the belt, on the zero "Y" plane.
- L205 CARGO LENGTH AT BELT — SECOND.** The minimum dimension measured horizontally from the back of the second seatback at the seatback top to the foremost normal surface of the closed tailgate at the height of the belt, on the zero "Y" plane.
- W201 CARGO WIDTH — WHEELHOUSE.** The minimum dimension measured laterally between the trimmed wheelhousings at floor level. For any vehicle not trimmed, measure the sheet metal.
- W203 REAR OPENING WIDTH AT FLOOR.** The minimum dimension measured laterally between the limiting interferences of the rear opening at floor level.
- W204 REAR OPENING WIDTH AT BELT.** The minimum dimension measured laterally between the limiting interferences of the rear opening at belt height or top of pick up box.
- W205 REAR OPENING WIDTH ABOVE BELT.** The minimum dimension measured laterally between the limiting interferences of the rear opening above the belt height.
- H201 CARGO HEIGHT.** The dimension measured vertically from the top of the undepressed floor covering to the headlining at the rear wheel "X" coordinated on the zero "Y" plane.
- H202 REAR OPENING HEIGHT.** The dimension measured vertically from the top of the undepressed floor covering to the upper trimmed opening on the zero "Y" plane with rear door fully open.
- H250 TAILGATE TO GROUND (CURB WEIGHT).** The dimension measured vertically from the top of the undepressed floor covering on the lowered tailgate to ground on the zero "Y" plane.

- V2 STATION WAGON**  
 Measured in inches:  

$$\frac{W4 \times H201 \times L204}{1728} = \text{Ft.}^3$$
  
 Measured in mm:  

$$\frac{W4 \times H201 \times L204}{10^9} = \text{m}^3 \text{ (cubic meter)}$$
- V4 HIDDEN CARGO VOLUME.** As specified by the manufacturer.

**Hatchback — Cargo Space Dimensions**  
 All hatchback cargo dimensions are to be taken with the front seat in full down and rear position, and the rear seat folded down. The hatchback door is in the closed position. (For electrically adjusted seats, see the manufacturer's specifications for Design "H" Point).

- H197 FRONT SEATBACK TO LOAD HEIGHT.** The dimension measured vertically from the horizontal tangent to the top of the seatback to the undepressed floor covering.
- L208 CARGO LENGTH AT FRONT SEATBACK HEIGHT.** The minimum horizontal dimension from the "X" plane tangent to the rearmost surface of the driver's seatback to the inside limiting interference of the hatchback door on the vehicle zero "Y" plane.
- L209 CARGO LENGTH AT FLOOR — FRONT — HATCHBACK.** The minimum horizontal dimension measured at floor level from the rear of the front seatback to the normal limiting interference of the hatchback door on the vehicle zero "Y" plane.
- V3 HATCHBACK.**  
 Measured in inches:  

$$\frac{L208 + L209}{2} \times W4 \times H197 = \text{Ft.}^3$$
  
 Measured in mm:  

$$\frac{L208 + L209}{2} \times W4 \times H197 = \text{m}^3 \text{ (cubic meter)}$$

# MVMA Specifications Form

## Passenger Car

### METRIC (U.S. Customary)

#### Index

Subject	Page No.
Alternator	12
Automatic Transmission	16
Axis, Steering	20
Axis, Rear	2, 16
Battery	12
Bearings, Engine	4, 6, 7
Belts — Fan, Generator, Water Pump	9
Brakes — Parking, Service	18, 19
Camber	20
Cams/Shaft	5
Capacities	
Cooling System	12
Fuel Tank	8
Lubricants	
Engine Crankcase	7
Transmission	18, 16
Rear Axle	16
Car Models	1
Car and Body Dimensions	
Width	26
Length	26
Height	26
Ground Clearance	26
Front Compartment	27
Rear Compartment	27
Luggage Compartment	27
Station Wagon — Third Seat	28
Station Wagon — Cargo Space	28
Hatchback — Cargo Space	28
Carburetor	2, 8, 11
Caster	20
Choke, Automatic	8
Clutch — Pedal Operated	15
Coil, Ignition	14
Connecting Rods	4
Convenience Equipment	23
Cooling System	9
Crankshaft	5
Cylinders and Cylinder Head	3
Dimension Definitions	
Key Sheet — Exterior	31, 33
Key Sheet — Interior	32, 34, 35
Distributor — Ignition	13
Electrical System	12, 13, 14
Emission Controls	10, 11
Engine	
Bore, Stroke, Type	3
Compression Ratio	2, 3
Displacement	2
Firing Order, Cylinder Numbering	3
General Information, Power & Torque	2, 3
Identification Number Location	22
Lubrication	7
Power Teams	2
Exhaust System	7
Equipment Availability	24
Fan, Cooling	9
Fiducial Marks	29
Filters — Engine Oil, Fuel System	7, 8
Frame	22
Front Suspension	21
Fuel, Fuel Pump, Fuel System	3, 8, 11
Fuel Injection	8
Generator and Regulator	12
Glass	30
Headroom — Body	27, 28
Heights — Car and Body	26
Horns	14
Horsepower — Brake	2
Ignition System	13, 14
Inflation — Tires	18
Instruments	14
Kingpin (Steering Axis)	20

Subject	Page No.
Lamp/Headlamp Shape	30
Legroom	27, 28
Lengths — Car and Body	26
Lifters, Valve	6
Linnings — Clutch, Brake	15, 19
Lubrication	7, 15, 16, 17
Luggage Compartment	27
Mass	27, 28
Masses	1
Motor, Starting	15
Muffler	10
Passenger Capacity	1
Passenger Mass Distribution	24
Piston/Pins & Rings	3, 4
Pistons	3, 4
Power/Brakes	18
Power/Engine	2
Power/Steering	20
Power Teams	2
Propeller Shaft, Universal Joints	17
Ramps — Oil, Fuel	7, 8
Radiator	9
Radiator — Cap, Hoses	9
Ratios — Axle	2, 16
Compression	2, 3
Steering	20
Transmission	18, 16
Rear Axle	2, 16
Regulator — Generator	12
Rims	18
Rings, Piston	4
Rods — Connecting	4
Seats	2
Shock Absorbers, Front & Rear	21
Spark Plugs	14
Speedometer	14
Springs — Front & Rear Suspension	21
Stabilizer (Sway Bar) — Front & Rear	21
Steering System	12
Steering	20
Supercharger — Ignition, Radio	14
Suspension — Front & Rear	21
Tail Pipe	7
Theft Protection	23
Thermostat, Cooling	9
Timing — Valve, Ignition	8, 13
Tires	18
Torque	20
Torque Converter	16
Torque — Engine	2
Transmission — Types	2, 8, 15, 16
Transmission — Automatic	2, 8, 15, 16
Transmission — Manual	2, 8, 15
Transmission — Ratios	18, 16
Washers	28
Wank/Cargo Load	1
Wank/Luggage Capacity	27
Wank/Diameter	20
Welded Construction	22
Universal Joints, Propeller Shaft	17
Valves — Intake & Exhaust	6
Vehicle Identification Number	22
Voltage Regulator	12
Water Pump	9
Weights	24, 25
Wheel Alignment	20
Wheelbase	26
Wheels & Tires	18
Wheel Spindle	1
Wipers — Car and Body	1
Windshield	1
Windshield Wiper and Washer	1-